

Carbon Dioxide Capture from Coal-Fired Power Plants: A Real Options Analysis

by

Ram Chandra Sekar

Bachelor of Technology (Honours), Indian Institute of Technology, Kharagpur, India (1992)
Master in Business Management, Asian Institute of Management, Metro Manila, Philippines (1996)

Submitted to the Engineering Systems Division
and the Department of Mechanical Engineering
in Partial Fulfillment of the Requirements for the Degrees of

Master of Science in Technology and Policy
and Master of Science in Mechanical Engineering

at the
Massachusetts Institute of Technology
June 2005

©2005 Massachusetts Institute of Technology. All rights reserved

Signature of Author _____
Engineering Systems Division and Department of Mechanical Engineering
6th May, 2005

Certified by _____
Henry D. Jacoby (Thesis Supervisor)
Co-Director, Joint Program on the Science and Policy of Global Change

Certified by _____
Howard J. Herzog (Thesis Supervisor)
Principal Research Engineer, Laboratory for Energy and the Environment

Certified by _____
David G. Laughton (Thesis Supervisor)
University of Alberta

Certified by _____
Ahmed Ghoniem (Thesis Reader)
Professor of Mechanical Engineering

Accepted by _____
Lallit Anand
Professor of Mechanical Engineering
Chairman, Departmental Committee on Graduate Studies

Accepted by _____
Dava J. Newman
Professor of Aeronautics and Astronomics and Engineering Systems
Director, Technology and Policy Program

Carbon Dioxide Capture in Coal-Fired Power Plants: A Real Options Analysis

by

Ram Chandra Sekar

Submitted to the Engineering Systems Division and
the Department of Mechanical Engineering on 6th May, 2005 in Partial Fulfillment of the
Requirements for
the Degrees of Master of Science in Technology and Policy and
Master of Science in Mechanical Engineering

ABSTRACT

Investments in three coal-fired power generation technologies are valued using the “real options” valuation methodology in an uncertain carbon dioxide (CO₂) price environment. The technologies evaluated are pulverized coal (PC), integrated coal gasification combined cycle (baseline IGCC), and IGCC with pre-investments that make future retrofit for CO₂ capture less expensive (pre-investment IGCC). All coal-fired power plants can be retrofitted to capture CO₂ and can be considered “capture-capable”, even though the cost and technical difficulty to retrofit may vary greatly. However, initial design and investment that take into consideration such future retrofit, makes the transition easier and less expensive to accomplish. Plants that have such an initial design can be considered to be “capture-ready”. Pre-investment IGCC can be considered to be “capture-ready” in comparison to PC and baseline IGCC on this basis. Furthermore, baseline IGCC could be taken as “capture-ready” in comparison to PC.

Cash flow models for specific cases of these three technologies were developed based on literature studies. The problem was formulated such that CO₂ price is the only uncertain cash flow variable. All cases were designed to have a constant net electric output before and after CO₂ retrofit. As a result, electricity price uncertainty had no differential impact on the competitive positions of the different technologies. While coal price was taken to be constant, sensitivity analysis were conducted to show the impact of varying coal prices.

Investment valuation was done using the “real options” approach. This approach combines (i) Market Based Valuation (MBV) to valuing cash flow uncertainty, with (ii) Dynamic quantitative modeling of uncertainty, which helps model dynamic retrofit decision making.

The thesis addresses three research questions:

- (i) What is the economic value of temporal flexibility in making the decision to retrofit CO₂ capture equipment?
- (ii) How does the choice of valuation methodology (DCF v. MBV) impact the investment decision to become “capture-ready”?
- (iii) Among the coal-fired power plant technologies, which should a firm choose to invest in, given an uncertain CO₂ policy? What are the economic factors that influence this choice?

The answers to the research questions strongly depend on the input assumptions to the cash flow and CO₂ price models, and the choice of representative cases of the technologies. For the specific cases analyzed in this thesis, it was found that investing in “capture-ready” power plants was not economically attractive.

Thesis Supervisors:

Henry D. Jacoby
Co-Director, Joint Program on the Science and Policy of Global Change
Massachusetts Institute of Technology

Howard J. Herzog
Principal Research Engineer, Laboratory for Energy and the Environment
Massachusetts Institute of Technology

David G. Laughton
University of Alberta

Acknowledgements

I would like to thank Howard Herzog for his guidance and support during my two years at the Carbon Sequestration Group. I would also like to thank the Carbon Sequestration Initiative for providing financial support for my research over this period.

I would like to acknowledge my thesis advisors Henry Jacoby, Howard Herzog and David Laughton who helped me understand and explore the interactions between technological options and investment valuation from an entirely new perspective. I would also like to thank Ahmed Ghoniem, my thesis reader, for his valuable comments and suggestions.

I acknowledge Linda Ye for her invaluable contribution in helping me decipher and modify the valuation code that David Laughton provided, and helping me with the numerous sensitivity runs.

My thanks go to Mary Gallagher for her support and to research assistants in the Carbon Sequestration Group for providing a stimulating research environment during my stay here. My special thanks go to Jim McFarland and Mark de Figueiredo from whom I learnt great deal from our lengthy discussions.

I would to thank my parents for encouraging me to excel in all my endeavors and being a constant source of inspiration. I'd like to thank our two-year old son Karun for enduring his dad's erratic schedule with a smile! I am indebted to my wife Priya whose endless patience, energy, support and encouragement helped me accomplish what I did during my two years at MIT.

Table of Contents

Acknowledgements.....	6
Table of Contents.....	7
List of Acronyms.....	9
List of Tables.....	10
List of Figures.....	11
1. Introduction and Problem Definition.....	13
2. CO ₂ Capture Retrofits - Technological Options.....	18
2.1 Technology Descriptions.....	18
2.1.1 Pulverized Coal (PC).....	18
2.1.2 Integrated Gasification Combined Cycle (IGCC).....	19
2.2 Technology Descriptions from Specific Cases: Non-Capture and Capture...	21
2.2.1 Pulverized Coal (PC).....	24
<i>PC without CO₂ Capture</i>	24
<i>PC With CO₂ Capture</i>	25
2.2.2 Baseline IGCC.....	26
<i>Baseline IGCC without CO₂ Capture (Case G-1a)</i>	26
<i>Baseline IGCC with CO₂ Capture (Case G-1b)</i>	27
2.2.3 Pre-Investment IGCC.....	30
<i>Pre-investment IGCC without CO₂ Capture (Case G-2a)</i>	30
<i>Pre-investment IGCC with CO₂ Capture (Case G-2b)</i>	31
2.3 Technical Performance.....	33
3. Problem Formulation.....	35
3.1 Problem Dimensions and Scope.....	36
4. Cash Flow Model.....	39
4.1 Investments.....	42
4.2 Fuel.....	43
4.3 O&M Costs.....	44
4.4 CO ₂ Emission Costs.....	45
4.5 Taxes.....	46
5. Carbon Dioxide Expert Price Elicitation and Stochastic Price Model.....	48
5.1 CO ₂ Price Elicitation.....	49
5.2 Quantitative Stochastic CO ₂ Price Model.....	52
6. Valuation Methodology.....	60
6.1 The Banff Taxonomy of Asset Valuation Methods.....	60
6.1.1 Modeling Uncertainty.....	61
6.1.2 Valuing Uncertainty.....	62
6.2 Preferred Approach to Valuation.....	65
6.3 Illustration of the Valuation Methods Applied.....	67
6.3.1 Deterministic DCF and MBV cases using DCF Scenarios and Risk Discounting with Forward Prices.....	68
6.3.2 American DCF and MBV cases using Complete DCF Decision Trees and Real Options Analysis.....	74
6.4 Research Question (i): What is the economic value of temporal flexibility of making the retrofit decision?.....	79

6.5	Research question (ii): How does the choice of valuation methodology (DCF v. MBV) impact the investment decision to become “capture-ready”?.....	84
7.	Analysis of Results	86
7.1	Economic Comparison of the Three Technologies.....	86
7.1.1	Comparison of Baseline IGCC and Pre-Investment IGCC.....	87
7.1.2	Comparison of Baseline IGCC and PC.....	89
7.1.3	Comparison of Three Technologies using Subject 2 and Subject 3 CO ₂ Prices.....	90
7.2	Analysis of Results of Economic Comparison	92
7.3	Sensitivity Analysis: Impact of Fuel Prices on Technology Choice.....	97
8.	Conclusions and Scope for Future Work	101
8.1	Conclusions.....	101
8.2	Scope for Future Work.....	103

List of Acronyms

\$/t	United States dollar per metric tonne
ASU	Air Separation Unit
atm	Atmospheres
BACT	Best Available Control Technology
Btu	British Thermal Unit
CEQ(X)	Certainty Equivalent of variable X
CF	Cash flow
CO	Carbon monoxide
CO ₂	Carbon dioxide
DCF	Discounted Cash Flow
E(X)	Expectation of variable X
EPRI	Electric Power Research Institute
FGD	Flue gas desulfurization
FP	Forward price
H ₂	Hydrogen
H ₂ S	Hydrogen Sulfide
Hg	Mercury
HRSG	Heat Recovery Steam Generator
IEA	International Energy Agency
IGCC	Integrated Gasification Combined Cycle
kWh	Kilowatt-hours electric
M(X)	Median of variable X
MBV	Market Based Valuation
MDEA	Methyldiethanolamine
MEA	Monoethanolamine
MIT	Massachusetts Institute of Technology
Mt	Million metric tonnes
MWh	Megawatt-hours electric
N ₂	Nitrogen
NO _x	Nitrogen oxides
NPV	Net Present Value
O&M	Operations and Maintenance
PC	Pulverized coal
P _{risk}	Price of risk
SCR	Selective Catalytic Reduction
SO _x	Sulfur oxides
t/MWh	metric tonne/Megawatt-hour
US	United States
US\$	United States dollar
WACC	Weighted Average Cost of Capital

List of Tables

Table 2.1: Specific cases for each technology.....	21
Table 2.2: Technical Comparison of PC, Baseline IGCC and Pre-investment IGCC.....	33
Table 3.1: Problem Dimensions and Scope.....	36
Table 4.1: Economic Comparison of PC, Baseline IGCC and Pre-investment IGCC.....	40
Table 4.2: Annual Fuel Costs for the Three Technologies at different Fuel Prices.....	44
Table 4.3: Annual O&M Costs for the Three Technologies.....	45
Table 4.4: CO ₂ Emissions for the Three Technologies Before and After Retrofit.....	46
Table 5.1: Results from the carbon price elicitation process (\$/t carbon).....	51
Table 5.2: Illustration of the Price Process.....	52
Table 5.3: 2010 CO ₂ Prices (\$/t) for the Three Subjects.....	56
Table 6.1: Values for Cash Flow Valuation Parameters.....	65
Table 6.2: Specific Case for Illustration.....	68
Table 6.3: Value of retrofit flexibility: Case description.....	80
Table 6.4: Case description for analyzing impact of valuation method on “capture-ready” technology.....	84
Table 6.5: Comparison of Cost NPV of the three technologies using MBV and DCF for illustrative case in Table 6.4 conditioned on median CO ₂ price in 2010.....	85
Table 7.1: Case description for comparing the technologies.....	87
Table 7.2: Case description for sensitivity analysis.....	98

List of Figures

Figure 2.1: PC without CO ₂ Capture	19
Figure 2.2: IGCC without CO ₂ Capture	20
Figure 2.3: PC without capture	24
Figure 2.4: Case 7A: PC retrofitted for CO ₂ capture	26
Figure 2.5: Case G-1a: Baseline IGCC without CO ₂ Capture	27
Figure 2.6: Case G-1b: Baseline IGCC Retrofitted for CO ₂ Capture	29
Figure 2.7: Case G-2a: Pre-investment IGCC without CO ₂ Capture	30
Figure 2.8: Case G-2b: Pre-investment IGCC retrofitted for CO ₂ Capture	31
Figure 5.1: Subject 1: Prices elicited and curve fitted by the model	57
Figure 5.2: Subject 2: Prices elicited and curve fitted by the model	58
Figure 5.3: Subject 3: Prices elicited and curve fitted by the model	58
Figure 5.4: Annual volatilities for the CO ₂ price models for the three experts. These volatilities are chosen through a trial-and-error process so as to fit (using H=4) the data elicited from the experts.	59
Figure 5.5: Shows the process of CO ₂ price reversion in Subject 3's price scenario. If the price in 2015 ends up being \$50/t CO ₂ , the median, 90th and 10th fractiles revert to the median, 90th and 10th fractiles conditioned on 2010.	59
Figure 6.1: The Banff Taxonomy of Asset Valuation Methods.	61
Figure 6.2: Pictographic representation of scenario generation for based on various approaches to modeling cash flow uncertainty	62
Figure 6.3: Preferred Valuation Approach	66
Figure 6.4: The cases for analysis formulated in Section 3.1 are overlaid on the Banff Taxonomy.	67
Figure 6.5: Cost NPV using DCF assuming deterministic retrofit is shown for the illustrative case.	71
Figure 6.6: Cost NPV using MBV and assuming deterministic retrofit is shown for the illustrative case.	71
Figure 6.7: Expected and Forward CO ₂ Prices conditioned on the median price in 2010.	73
Figure 6.8: Effective discounting rates per year for CO ₂ emissions costs using DCF and MBV.	73
Figure 6.9: The cost NPV plotted against different CO ₂ prices in 2010 for both DCF and MBV assuming American option on retrofit.	78
Figure 6.10: The cumulative retrofit probability over time for MBV and DCF for the illustrative case.	79
Figure 6.11: Value of retrofit flexibility determined as the reduction in cost NPV using MBV.	81
Figure 6.12: Cumulative retrofit probability for Pre-investment IGCC using MBV and assuming flexibility in retrofit decision making	83
Figure 7.1: Cost NPV of pre-investment IGCC and baseline IGCC for difference prices of CO ₂ in 2010.	88
Figure 7.2: Cost NPV difference between Pre-investment IGCC and Baseline IGCC.	88
Figure 7.3: Cost NPV of baseline IGCC and PC for difference prices of CO ₂ in 2010.	89
Figure 7.4: Cost NPV difference between baseline IGCC and PC.	90
Figure 7.5: Cost NPV difference between pre-investment IGCC and baseline IGCC	91
Figure 7.6: Cost NPV difference between baseline IGCC and PC.	92
Figure 7.7: Subject 1: Cumulative retrofit probabilities of pre-investment and baseline IGCC.	93
Figure 7.8: Subject 2: Cumulative retrofit probabilities of pre-investment and baseline IGCC.	94
Figure 7.9: Subject 3: Cumulative retrofit probabilities of pre-investment and baseline IGCC.	94
Figure 7.10: Subject 1: Cumulative retrofit probabilities of PC and Baseline IGCC.	96
Figure 7.11: Subject 2: Cumulative retrofit probabilities of PC and baseline IGCC.	96
Figure 7.12: Subject 3: Cumulative retrofit probabilities of PC and baseline IGCC.	97
Figure 7.13: Cost NPV difference between baseline IGCC and PC for three fuel prices.	98
Figure 7.14: Cumulative retrofit probabilities for PC and baseline IGCC for a fuel price of \$1.5/million Btu.	100
Figure 7.15: Cumulative retrofit probabilities for PC and baseline IGCC for a fuel price of \$2/million Btu.	100

1. Introduction and Problem Definition

Coal is a very attractive energy source for electric power production in the United States because it is relatively inexpensive compared to other fossil fuel sources for this purpose.¹ Further, domestic reserves of coal are substantially larger than those of other fossil fuel sources,² and this makes coal a more favored fuel source from an energy security viewpoint. However, the combustion of coal results in emission of carbon dioxide (CO₂), the largest anthropogenic source of greenhouse gases in the US.³ Coal-fired power plants contributed to 50% of total electric power produced in the United States in 2004,⁴ and 30% of the net anthropogenic CO₂ emissions in the US in 2002.⁵

Coal plants, once built, operate for a very long time at close to rated capacities. As of 2003, the capacity-weighted average age of the coal plant fleet in the US was 33 years.⁶ This implies that coal plants, once constructed, will steadily emit CO₂ over a long period. National Energy Technology Laboratory's study on the resurgence of coal in electric power generation indicates that over 42% of the additional electric capacity over the next twenty years is going to be coal-based. This implies that the existing problem of CO₂ emissions from coal power plants is very likely to be compounded in the future.

Anthropogenic CO₂ emissions are being increasingly viewed as a problem by policy makers in the US, and it is reasonable to expect that they may be regulated in the future. Against this backdrop, it becomes increasingly important to consider building flexibility into coal-fired power plant design such that they can be retrofitted efficiently,

¹ Electric Power Monthly, March 2005, Energy Information Administration, US Department of Energy.

² Ibid.

³ 2004 Inventory of U.S. Greenhouse Gas Emissions and Sinks; US Environmental Protection Agency.

⁴ Electric Power Monthly, March 2005, Energy Information Administration, US Department of Energy.

⁵ 2004 Inventory of U.S. Greenhouse Gas Emissions and Sinks; US Environmental Protection Agency.

both from a technical and economic perspective, to capture CO₂. CO₂ is captured with the intention of being stored. The analysis of CO₂ storage is beyond the scope of the thesis.

All coal-fired power plants can be retrofitted to capture CO₂. So, even though the cost and technical difficulty to retrofit may vary greatly, all coal-fired power plants can be considered “capture-capable”. However, initial design and investment that take into consideration such future retrofit, makes the transition easier and less expensive to accomplish. Plants that have such an initial design can be considered to be “capture-ready”.

This thesis will consider three coal-fired power plant options – Pulverized Coal (PC), Baseline Integrated Gasification Combined Cycle (Baseline IGCC) and Pre-investment IGCC. The PC technology can be considered, for our purposes, to be “capture-capable”. While the PC is the cheapest in terms of capital costs,⁷ it is the most expensive to retrofit for CO₂ capture. The pre-investment IGCC, on the other hand, has the highest cost upfront but is the cheapest to retrofit. Baseline IGCC falls somewhere in the middle.

Most research programs^{8 9} and literature¹⁰ on CO₂ capture in coal-fired power plants focus largely on technical aspects and overlook the investment valuation aspects.

⁶ Based on information in the Annual Electric Generator Report, 2003; Energy Information Administration, US Department of Energy.

⁷ Infra Chapter 2.

⁸ Environment Technology Council, US Environmental Protection Agency (October 2004): Coal Gasification Team: "Should options address carbon capture ready technology and carbon sequestration opportunities?"

⁹ Carbon Capture Research – Department of Fossil Energy; <http://www.fossil.energy.gov/programs/sequestration/capture/index.html>; “Development of retrofitable CO₂ reduction and capture options for existing large point sources of CO₂ emissions such as electricity generation units.”

Some studies that do provide economic analyses of capture-readiness¹¹ lack the rigor and conceptual bases required for such effort.

This thesis takes the perspective of a firm that is deciding to invest in a new coal-fired generation facility. The firm has the choice to pick a preferred technology, and also has the option to retrofit CO₂ capture equipment when it is most economical to do so. This option can be very valuable, since it can delay substantial capital investment required for retrofit. The valuation of the investment, incorporating the option to capture CO₂, is done using the Market Based Valuation (MBV) approach. Traditionally, investors have valued their investments in power plants using the standard Discounted Cash Flow (DCF) approach without explicitly considering the economic value of flexibility in their plant designs.

The value of a cash flow is determined by its uncertainty and timing. In the DCF method, cash flows are discounted for time and risk at the Weighted Average Cost of Capital (WACC). All components of cash flow are discounted at the same WACC irrespective of the very different risks associated with each. The MBV approach attempts to correct this flaw, by adjusting different cash flow variables for risks, and discounting the risk-adjusted cash flows for time at the risk-free rate.

When options to modify plant configuration and operations are not considered, point forecasts and simple scenarios (high, medium and low) of cash flows often suffice for valuation purposes. Of late, Monte-Carlo cash flow simulation methods have been

¹⁰ 7th International Conference on Greenhouse Gas Control Technologies; Vancouver, Canada; Accelerated Adoption of Carbon Dioxide Capture and Storage Within the United States Utility Industry: The Impact of Stabilizing at 450 ppmv and 550 ppmv; J.J. Dooleya, I, C.L. Davidsonb, M.A. Wisea, R.T. Dahowskib; September 2004.

¹¹ Phased Construction of IGCC Plants for CO₂ Capture – Effect of Pre-Investment: Subtitle, Low Cost IGCC Plant Design for CO₂ Capture, EPRI, Palo Alto, CA, 2003. 1004537

used in place of simple scenarios to incorporate cash flow uncertainty. In order to value dynamic decision making, we need both a dynamic model of how uncertainty is resolved over time, and a search algorithm that optimizes sequential decision rules taking into account this evolving uncertain future. Dynamic programming is one such algorithm, and the thesis assesses the retrofit option value using this approach, addressing the following questions:

- (i) What is the economic value of temporal flexibility in making the retrofit decision?
- (ii) How does the choice of valuation methodology (DCF v. MBV) impact the investment decision to become “capture-ready”?
- (iii) Among the coal-fired power plant technologies, which should a firm choose to invest in, given an uncertain carbon policy? What are the economic factors that influence this choice?

Although the value of such a tool to a firm is obvious, this could also aid policy makers in analyzing their roles in influencing investor choices of technological alternatives in an uncertain carbon policy scenario. An investor’s choice of technology is influenced by capital and operating costs of the different technologies before and after retrofit, carbon prices and their uncertainties, and fuel prices. Policy makers can play a role in influencing each of these costs, either directly or indirectly. Selective financial incentives to specific technologies in the form of loan guarantees and investment tax credits effectively reduce capital costs, and alter competitive positions. Another method by which policy makers could promote nascent technologies, which are not cost

competitive today, is by enhancing support for support for their research, development, demonstration and deployment. The initial “hand-holding” could help these technologies to diffuse, and eventually improvement their cost competitiveness. Such diffusion could help reduce capital and operating costs. A “cap-and-trade” or best available control technology (BACT)¹² carbon policy will help the market generate an implied uncertain carbon price path that could influence technology choice. The tool developed in the thesis can help in the analysis of various investment alternatives in such dynamic policy environments.

At the outset of the thesis, the technical and economic details of the technological options to be valued are discussed in Chapter 2. Chapter 3 describes the problem formulated for investment valuation so as to help answer the research questions discussed in this chapter. Chapter 4 details the cash flow model for valuation and the choice of the uncertain variables in this model, in the context of the problem formulated in Chapter 3. Chapter 5 provides a summary of the expert elicitation of the uncertain variables chosen in Chapter 4. It describes the quantitative model of the uncertainty involved, which will be integrated into the cash flow model described in Chapter 4. Chapter 6 describes the methodology for investment valuation of cash flows in the stochastic cash flow model for different retrofit decision making approaches. Chapter 7 provides an analysis of the results obtained from carrying out the investment valuation for the problem formulated in Chapter 3, using the methodology discussed in Chapter 6. Chapter 8 provides the conclusion and lays out the scope for future work.

¹² Implementation of a BACT technology for CO₂ emissions will take CO₂ price uncertainty out of the investment valuation process.

2. CO₂ Capture Retrofits - Technological Options

In order to understand the technical and economic considerations of CO₂ capture retrofits and associated economic impacts, it is important to first understand generic PC and IGCC technologies. The chapter provides a technical description of these basic technologies in non-capture modes. This is followed by process descriptions from literature of specific PC, baseline IGCC and pre-investment IGCC cases in non-capture and capture configurations. An overview of the differences between these configurations for each technology is provided to help understand process modifications and equipment additions for CO₂ retrofit. A comparison of the technical performance and costs for the three cases is provided.

2.1 Technology Descriptions

2.1.1 *Pulverized Coal (PC)*

Coal and air are combusted in a boiler to produce high pressure steam to drive a steam turbine, which in turn is coupled to a generator that produces electricity (see Figure 2.1). The low pressure steam that exits the steam turbine is condensed and pumped back to the boiler for conversion to steam. The cycling of energy in the working fluid (steam) for conversion of thermal energy of the fuel to useful electric energy follows what is called the Rankine cycle.

The flue gases from the boiler are sent through a gas clean up process to remove particulates and acid gases. The gases emitted through the stack to the atmosphere

contain CO₂ (typically 13%-15% by volume¹³), and are at pressures close to atmospheric pressure.

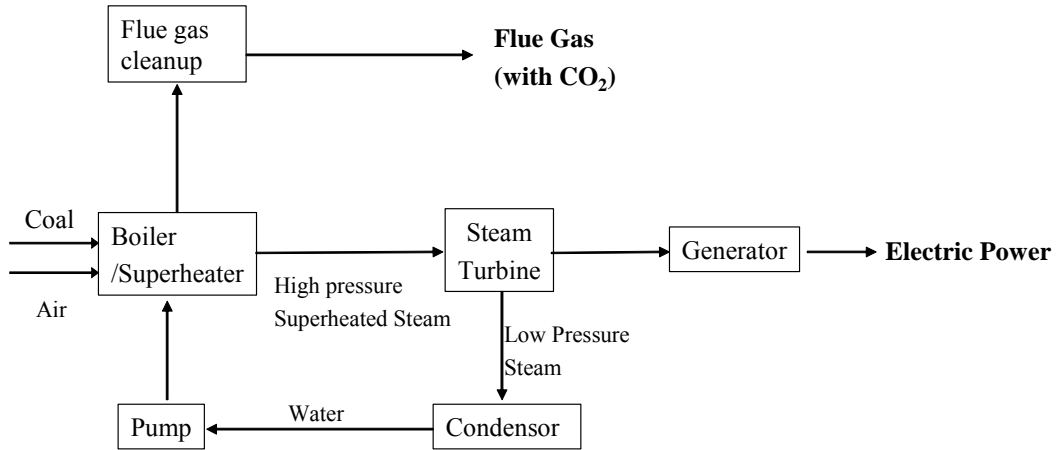

Figure 2.1: PC without CO₂ Capture

2.1.2 Integrated Gasification Combined Cycle (IGCC)

An IGCC process is one where oxygen from an air separation unit (ASU) and coal are combusted under pressure in a gasifier to produce a synthesis gas (syngas), which is primarily as mixture of carbon monoxide (CO) and hydrogen (H₂) (see Figure 2.2). The syngas is cleaned and used as a fuel in a gas-turbine-generator system to produce electric power. Air is compressed in the gas-turbine-generator system, mixed with syngas and combusted to produce flue gases at high temperature and pressure. The flue gases are passed through a gas-turbine-generator system to produce electric power. The conversion of thermal energy of the air-syngas mixture to electricity in the gas-turbine system follows what is called the Brayton cycle.

¹³ Howard Herzog, "What Future for Carbon Capture and Sequestration" in Environmental Science and Technology, April 1, 2001 / Volume 35 , Issue 7 / pp. 148 A – 153 A.

A fraction of the high pressure air from the combustor may be partially “integrated” into the air separation unit for producing oxygen and nitrogen. Also, the nitrogen from the air-separation unit may be integrated with the gas-turbine system to reduce gas turbine temperatures and NO_x formation, and to increase electric output of the gas-turbine-generator system.¹⁴

The exhaust gases from the gas-turbine-generator system are passed through a Heat Recovery Steam Generator (HRSG) to produce high pressure steam. This steam is sent to a steam turbine system to produce electric power, in the same way as power is generated in a PC process. The cycling of energy of from the HRSG through the steam-turbine-generator follows the Rankine cycle. Flue gases from the HRSG, which contain CO₂, are vented through a stack. The combination of the “topping” Brayton cycle in the gas-turbine-generator and the “bottoming” Rankine cycle in the steam-turbine-generator is called “combined-cycle” operation.

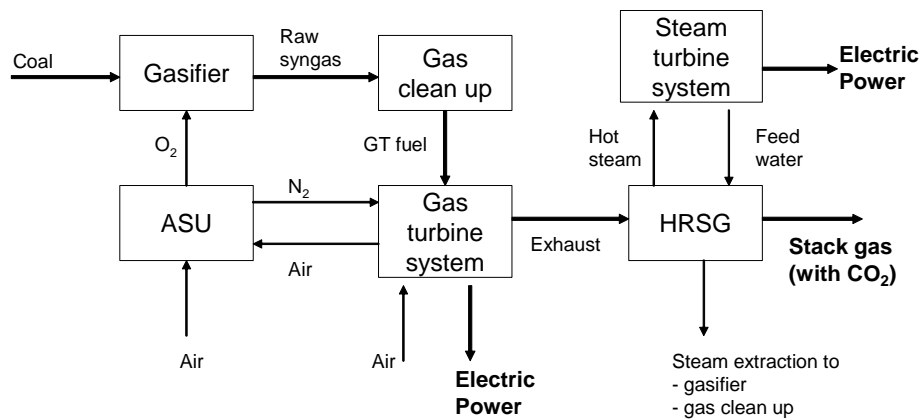

Figure 2.2: IGCC without CO₂ Capture¹⁵

¹⁴ Neville Holt (2001). “Integrated Gasification Combined Cycle Plants”. Encyclopedia of Physical Science and Technology, 3rd Edition.

¹⁵ Ola Maurstad, personal communication.

2.2 Technology Descriptions from Specific Cases: Non-Capture and Capture

This section provides a brief description of capture and non-capture technology for three specific cases: PC¹⁶, baseline IGCC¹⁷ and pre-investment IGCC¹⁸. The specific cases considered for each technology are listed in Table 2.1. The studies referred to in the table provide detailed process descriptions for the specific cases.

Table 2.1: Specific cases for each technology

Technology	Case without CO₂ Capture	Case with CO₂ capture	Study
PC			<i>Case constructed based on several published studies</i> ⁶
Baseline IGCC	G-1a	G-1b	<i>Phased Construction of IGCC Plants for CO₂ Capture; EPRI December 2003</i>
Pre-investment IGCC	G-2a	G-2b	<i>Phased Construction of IGCC Plants for CO₂ Capture; EPRI, December 2003</i>

The EPRI study on the Phased Construction of IGCC for CO₂ Capture is the only study available that approaches retrofit from a phased construction perspective for different initial plant configurations. The Baseline and Pre-investment IGCC cases in this study were consistent in the underlying assumptions, and were obvious cases to include in the analysis. It became essential to find a PC case that was consistent with the chosen IGCC cases. A list of studies with PC and IGCC cases, with and without capture,

¹⁶ Case constructed based on previous PC studies.

¹⁷ Phased Construction of IGCC Plants for CO₂ Capture – Effect of Pre-Investment: Subtitle, Low Cost IGCC Plant Design for CO₂ Capture, EPRI, Palo Alto, CA, 2003.

¹⁸ Ibid.

were reviewed¹⁹ and the technical and economic cost differences between IGCC and PC before capture and between PC with capture and PC without capture were compiled. These differences were then used to construct PC cases that were consistent with the chosen IGCC cases.

Sub-critical air-fired PC technology was chosen, given that they represent the most ubiquitous technology in the power plant fleet today. The CO₂ capture technology assumed is flue gas scrubbing, which is the only technique which is essentially commercial today. PC technologies designed to reduce CO₂ separation costs by assuming oxy-firing and flue gas re-circulation are undergoing trials on a 5MW scale.²⁰

Capture technologies closest to being commercialized for large scale IGCC operation have been assumed in the cases assumed. The different commercial and non-commercial options available discussed in literature²¹ for capturing CO₂ emissions from an IGCC plant are the following:

¹⁹ The following studies were reviewed with the assistance of Mark Bohm and Manuela Ueda at the Carbon Sequestration Group, MIT.

- (i) Evaluation of Innovative Fossil Fuel Power Plants with CO₂ Removal: Interim Report, December 2000, EPRI.
- (ii) Rubin, E.S., A.B. Rao and C. Chen, 2004: .Comparative Assessments of Fossil Fuel Power Plants with CO₂ Capture and Storage,. In, E.S.Rubin, D.W.Keith and C.F.Gilboy (Eds.), Proceedings of 7th International Conference on Greenhouse Gas Control Technologies. Volume 1: Peer-Reviewed Papers and Plenary Presentations, IEA Greenhouse Gas Programme, Cheltenham, UK.
- (iii) NETL-DOE (National Energy Technology Laboratory and the United States Department of Energy), 2002: Worldwide Gasification Database online, Pittsburgh, PA, USA.
- (iv) Nsakala, N, G. Liljedahl, J. Marion, C. Bozzuto, H. Andrus, and R. Chamberland, 2003: Greenhouse gas emissions control by oxygen firing in circulating fluidized bed boilers. Presented at the Second Annual National Conference on Carbon Sequestration. Alexandria, VA May 5 - 8, USA.
- (v) Opportunities to expedite the construction of new coal-based power plants; Final Draft December 2004, National Coal Council.

²⁰ Brian McPherson (2004). South West Regional Partnership on Carbon Sequestration, Semi-Annual Report: Reporting Period May 1, 2004 to September 30, 2004.

<http://www.osti.gov/bridge/servlets/purl/836636-u2iS78/native/836636.pdf>

²¹ Gerold Gottlicher (2004). "The Energetics of Carbon Dioxide Capture in Power Plants." NETL, US Department of Energy English Translation of "Energetik der Kohlendioxidruckhaltung in Kraftwerken." Fortschritt-berichte VDI Reihe 6 Nr.421.

- (i) Flue gas scrubbing for CO₂ capture after combustion of syngas in the gas turbine.
- (ii) Scrubbing of shifted syngas (CO₂+H₂) to capture CO₂. This results in H₂ being combusted in the gas turbine.
- (iii) Membrane processes for separating CO₂ out of shifted syngas. Alternatively, membrane reactors that combine the shifting of syngas and separation of CO₂ and H₂ could be used.
- (iv) Another way of removing CO₂ from coal-fired power plants is decarbonization (removal of carbon from the coal) using a hydrolysis reactor to convert coal to methane rich fuel gas, followed by a methane cleavage reactor process to produce C and H₂ from CH₄. The result is a H₂ rich gas that could be combusted in a gas turbine.
- (v) By burning coal in an atmosphere consisting of oxygen and CO₂/steam (using recirculated flue gas), with the exclusion of other inert gases, it is possible to produce an exhaust gas of only CO₂ and H₂O. This requires a turbine that can operate using CO₂/H₂O as the working fluid.
- (vi) CO₂ could be removed from shifted syngas produced from coal gasification, and the hydrogen could be used to generate power using fuel cells. Another option is to use the fuel with the carbon in the fuel cell, and removed the carbon from the residual fuel in the anode exhaust gas.

At the current levels of technology, (i) and (ii) can be built on a commercial scale. (iii) is not available on a commercial scale yet. Literature shows very low energy

efficiency of a power plant using (iv). (v) is not feasible today as a turbine operating on CO₂+steam does not exist, even though, in principle, it may be believed that the technology exists for combustion in an atmosphere of O₂/CO₂. (vi) is still in the development stage. It is seen that (ii) is economically more attractive than (i).

2.2.1 Pulverized Coal (PC)

PC without CO₂ Capture

The PC plant without capture (see Figure 2.3) has a selective catalytic reduction (SCR) process to remove NO_x, an Electrostatic Precipitator to remove particulate material, and a wet limestone forced oxidation flue-gas de-sulfurization (FGD) is used to control SO_x emissions. A once-through boiler is used to power a double-reheat sub-critical steam turbine.

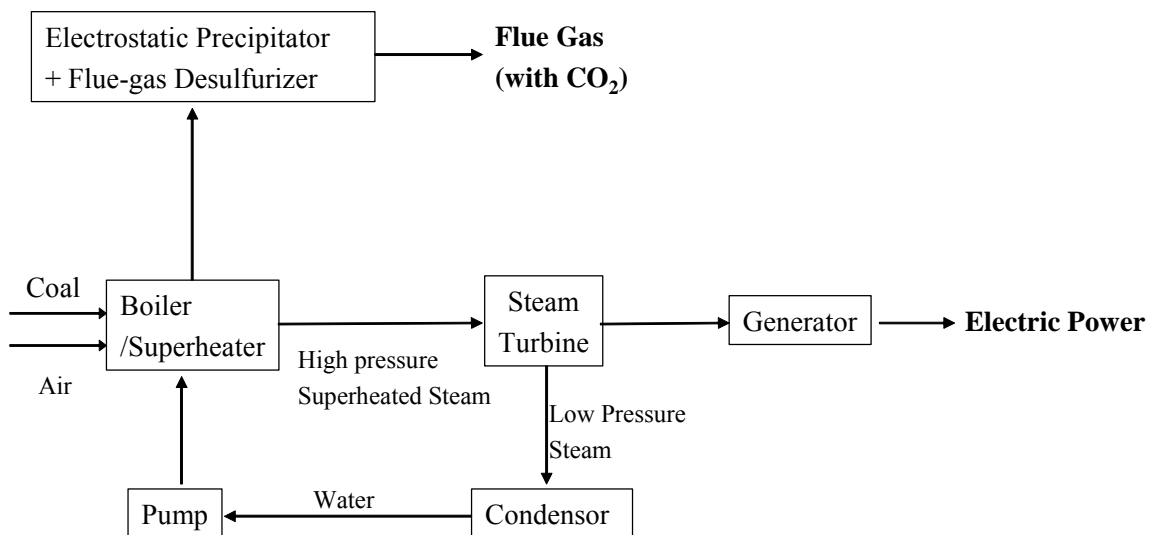

Figure 2.3: PC without capture

PC With CO₂ Capture

When an existing PC plant is retrofitted for CO₂ capture, the major new technological units that get added to the existing plant (see Figure 2.4), which reduces the net electric efficiency, are:

(i) The MEA process

The flue gas exiting the FGD system is routed to an inhibited Monoethanolamine (MEA) absorber-stripper system. The solution of aqueous MEA is used to remove 90% of the CO₂ in the flue gas. Low-pressure steam ($\sim 5 \text{ bar}^{22}$) is used to strip the CO₂ from the solvent.

The blower for flue gas to overcome pressure drop in the absorber consumes parasitic power, which results in reduced electric output. A lesser amount of electricity is needed to pump the amine solution around the process. The slip stream in the steam turbine used to strip CO₂ from the solvent leads to lesser available steam for electric power generation, and results in reduced electric output.

(ii) The CO₂ compression unit is designed to compress the CO₂ removed from the MEA process to the supercritical pressure of CO₂ (75 atmospheres) for transport and sequestration. The electric power required for the CO₂ compression represents another source of parasitic load.

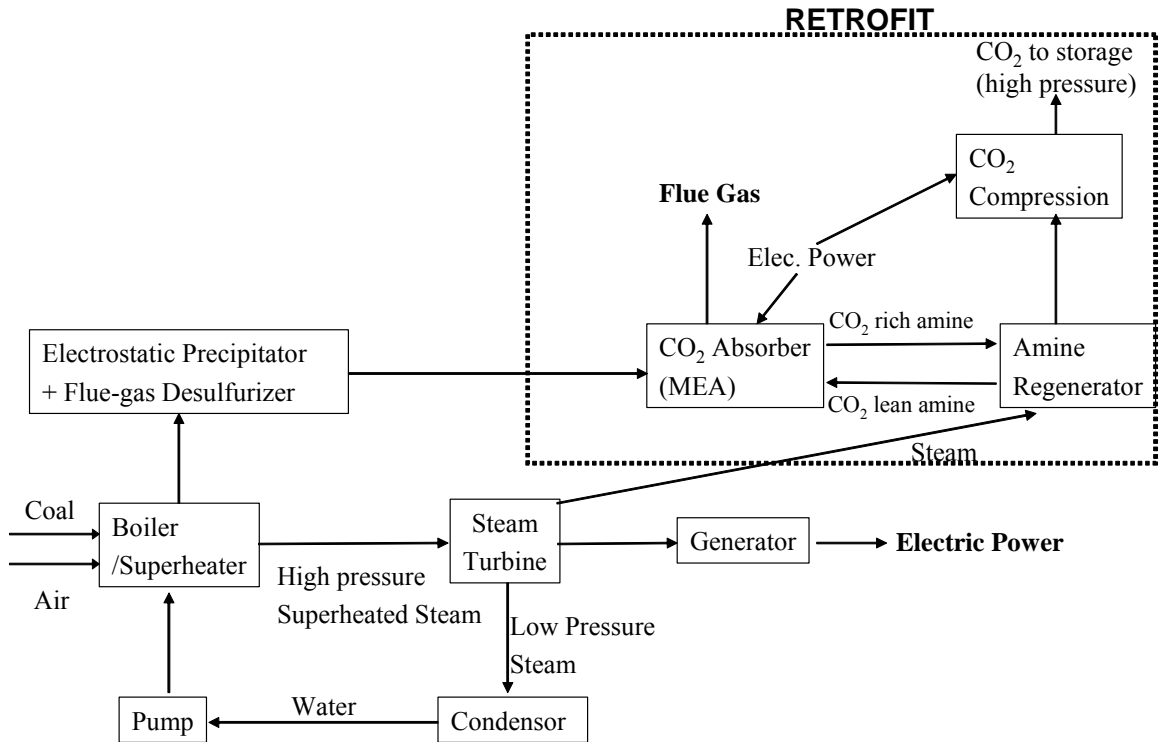

Figure 2.4: Case 7A: PC retrofitted for CO₂ capture

2.2.2 Baseline IGCC

Baseline IGCC without CO₂ Capture (Case G-1a)

The process in this case (see Figure 2.5) is similar to that described in the generic IGCC process described in the section 2.1.2. In this specific case, the syngas is then treated for mercury removal, after which goes through the Methyldiethanolamine (MDEA) process for removal of acid gases like H₂S. The clean syngas is then used as fuel to run a combined cycle power plant to produce electricity. The flue gases from the gas turbine would include a substantial portion of CO₂.

²² http://www.esru.strath.ac.uk/EandE/Web_sites/02-03/carbon_sequestration/

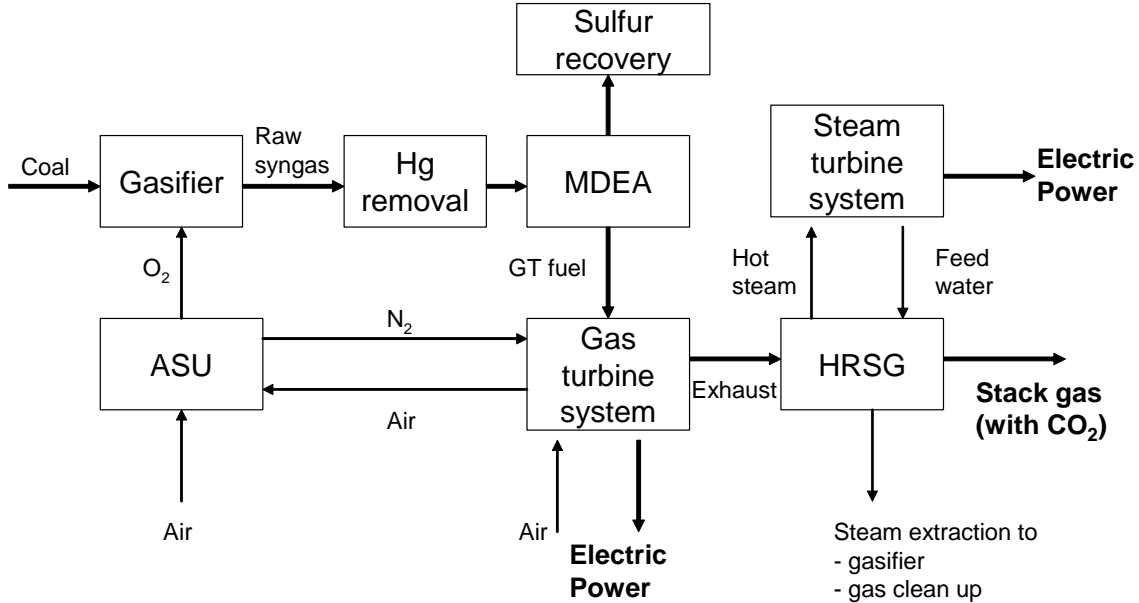
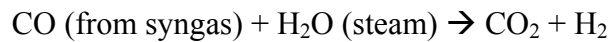

Figure 2.5: Case G-1a: Baseline IGCC without CO₂ Capture

Baseline IGCC with CO₂ Capture (Case G-1b)

In an IGCC plant retrofitted for CO₂ capture (see Figure 2.6), the syngas (CO +H₂) coming out of the gasifier reacts with steam to produce CO₂ and H₂. This reaction is called the water-gas shift (“shift”) reaction and happens in the shift reactor.



The energy required for conversion of water to steam for the shift reaction is a major factor that reduces efficiencies of IGCC plants retrofitted for CO₂ capture. In the specific case considered, the shift reaction happens in three stages. The first two of these three stages of shift are at high temperature, while the third is at low temperature. This is designed to optimize the conversion of CO to CO₂, and increase the concentration of H₂

in the exit stream of the low temperature shift reactor. The shifted syngas is cleaned for mercury, and passed through a two-stage selexol process. The selexol process separates acid gases from the shifted syngas by physical absorption and regeneration. This process can be used, instead of the traditional amine process because the acid gas is at a relatively high pressure, and the concentration of CO₂ is high. The selexol process, in two stages, separates H₂S (source of SO_x emission), CO₂ and H₂ from the shifted syngas. The H₂S is sent for sulfur removal and recovery, the CO₂ is compressed and made ready for capture and the H₂ is sent to the gas-turbine system for electric power generation.

From the above description, it becomes evident that retrofitting a baseline IGCC for CO₂ capture involves substantial changes in gas streams going to different process units. In a PC plant, the process integration of post-combustion capture equipment is relatively less complex.

On the other hand, the cost of recovering CO₂ post-combustion in PC plants using the chemical absorption (amine process) is higher than that of recovering CO₂ pre-combustion using physical absorption (selexol process) in IGCC plants. This cost differential is driven primarily by the difference in CO₂ partial pressures in the chemical and physical absorption processes. Lower CO₂ partial pressure in chemical absorption causes greater parasitic losses that result in higher CO₂ recovery costs. Further, post-combustion capture processes (typically chemical absorption) handle substantial higher volume of gas than do pre-combustion capture processes (typically physical absorption). This means that the scale and capital cost of the capture plant is much higher for post-combustion capture than it is for pre-combustion capture. Also, post-combustion

processes also have significant solvent losses, and have higher parasitic losses than do pre-combustion processes.²³

Therefore, while the upfront cost of building IGCC plants without CO₂ capture are higher than that of PC plants, the capital and operating costs of CO₂ capture facilities for IGCC plants are lower than those for PC plants.

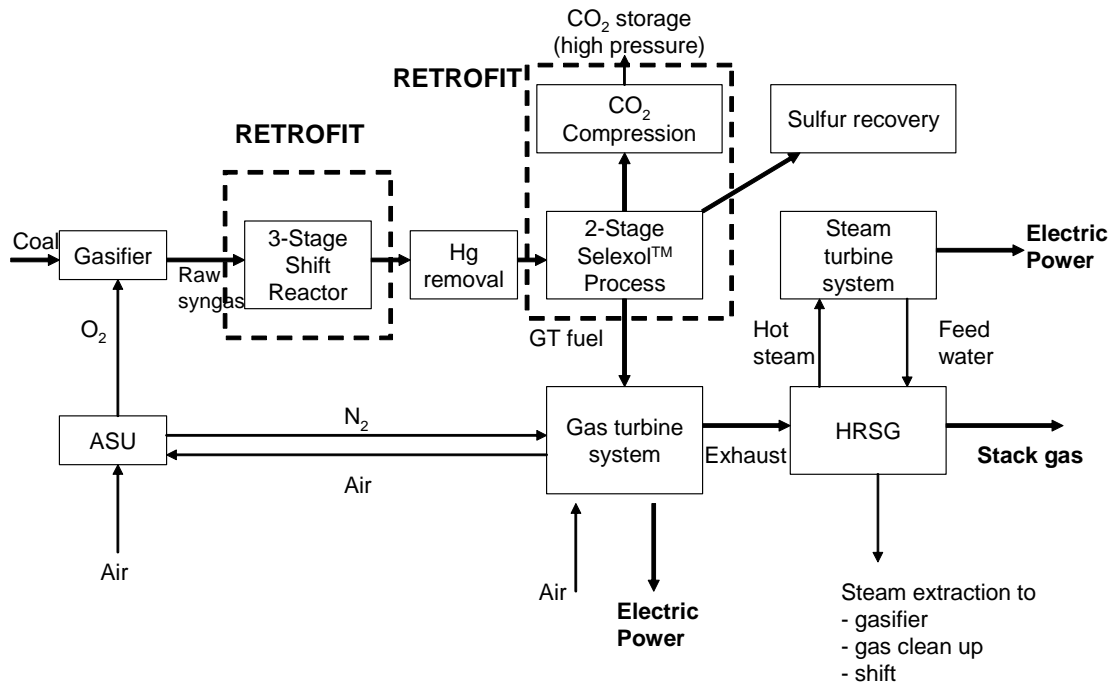

Figure 2.6: Case G-1b: Baseline IGCC Retrofitted for CO₂ Capture

The main pieces of equipment that get added when a retrofit is done on a baseline IGCC are:

- (i) Shift reactors
- (ii) Selexol unit; the MDEA process in the baseline IGCC is removed.

²³ Herzog, H.J. and D. Golomb, "Carbon Capture and Storage from Fossil Fuel Use," in C.J. Cleveland (ed.), Encyclopedia of Energy, Elsevier Science Inc., New York, pp 277-287, (2004)

- (iii) CO₂ compressors
- (iv) Gas turbines in the power island need to be retrofitted to burn H₂ rich gas.
- (v) Steam turbines need to be rebuilt to account for lower heat transfer input to the heat recovery steam generators.

2.2.3 Pre-Investment IGCC

Pre-investment IGCC without CO₂ Capture (Case G-2a)

The motivation behind a pre-investment IGCC design is to make CO₂ retrofit easier than it is for a baseline IGCC plant. The pre-investment IGCC in this specific case is designed such that its electric power output is the same as that of a baseline IGCC described in Section 2.2.2. A block diagram of a pre-investment IGCC without CO₂ capture is shown in Figure 2.7.

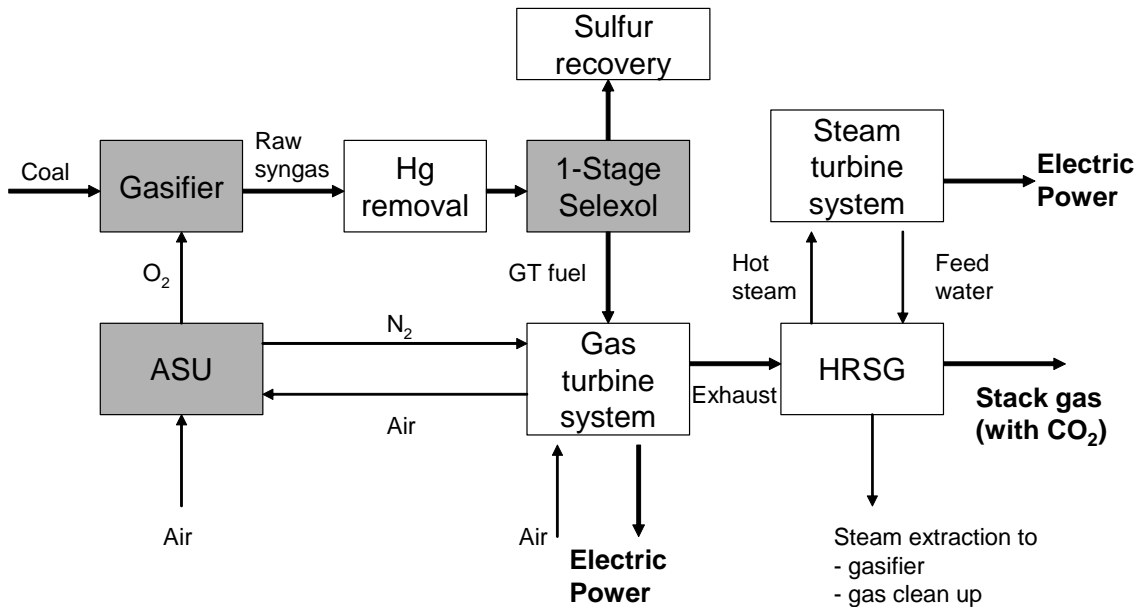

Figure 2.7: Case G-2a: Pre-investment IGCC without CO₂ Capture. Shaded boxes show sub-units which are oversized when compared to a baseline IGCC. This oversized makes pre-investment IGCC more expensive than baseline IGCC, but it also makes retrofit in a pre-investment IGCC easier and cheaper compared to a baseline IGCC, thus giving it a “capture ready” character.

In order to meet the output objectives, the pre-investment IGCC plant without CO₂ capture needs to be over-designed. The gasifier and air-separation unit capacities (and associated systems) should be adequate enough such that the syngas fuel input before CO₂ retrofit, and the H₂ fuel input after CO₂ retrofit produce equal electric outputs in the gas-turbine system. This means that there is extra capacity in the gasifier and ASU that is not utilized until the pre-investment IGCC has not been retrofitted for CO₂ capture.

Further, a single-stage selexol process is provided for H₂S removal, and is configured in such a way that additional stages can be added for CO₂ separation during the retrofit.

Pre-investment IGCC with CO₂ Capture (Case G-2b)

A block diagram of a pre-investment IGCC retrofitted for CO₂ capture is shown in Figure 2.8.

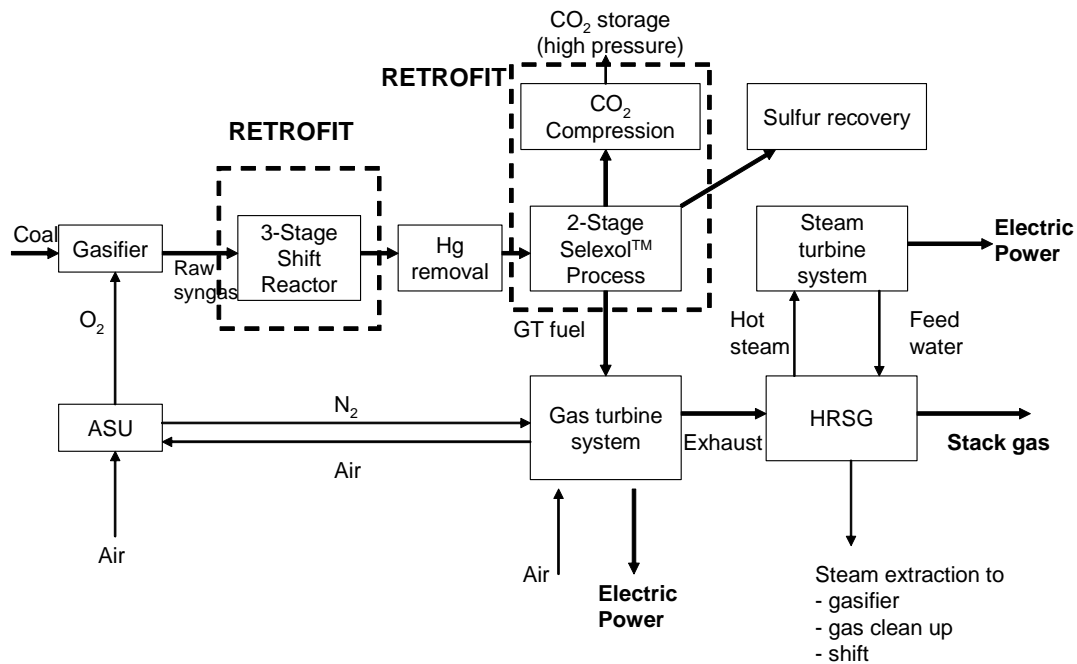

Figure 2.8: Case G-2b: Pre-investment IGCC retrofitted for CO₂ Capture

The main facility changes required to retrofit a pre-investment IGCC that is capture-ready for CO₂ capture are the following:

- (i) The pre-investment IGCC plant has a one-stage selexol process for acid gas removal. When this pre-investment IGCC is retrofitted for CO₂ capture, another stage of the selexol process is added to remove CO₂.
- (ii) The pre-investment IGCC plant does not have any shift-reactors. When it is retrofitted for CO₂ capture, three stages of shift are added.
- (iii) CO₂ compressors

The extent of reconfiguration of equipment in retrofitting a pre-investment IGCC plant is substantially lower than that of a baseline IGCC plant. The gasifier and air-separation unit in a pre-investment IGCC plant operating without CO₂ capture are designed such that they don't need to be modified when the plant is retrofitted for CO₂ capture. Further, neither the gas turbine system nor the steam turbine system requires any modification. This is because energy input to the gas turbine, and the steam input to the steam turbine-system do not change before and after retrofit.

The pre-investment IGCC does not include a MDEA stage as does the baseline IGCC. A single-stage selexol, with the provision for an additional stage, does the job of the MDEA in the baseline IGCC without capture. On retrofit of a baseline IGCC, the MDEA has to be removed and a two-stage selexol has to be introduced. On the other hand, while retrofitting a pre-investment IGCC, an additional selexol stage has to be introduced. Further, the retrofit in a pre-investment IGCC is made easier by the space provided in the design for three shift reactors, and an additional selexol stage.

2.3 Technical Performance

A summary of the key technical indicators of the technologies described in the earlier sections is provided in the Table 2.2.

Table 2.2: Technical Comparison of PC, Baseline IGCC and Pre-investment IGCC

TECHNICAL COMPARISON			
	Before Retrofit	After Retrofit	Change
Net Electric Output (MW_e)			
PC	462	329	-28.7%
Baseline IGCC	513	396	-22.9%
Pre-investment IGCC	513	429	-16.4%
Net Heat Rate (Btu/KWh_e)			
PC	9501	13301	+40.0%
Baseline IGCC	8637	11204	+29.7%
Pre-investment IGCC	8637	11205	+29.7%
Thermal Efficiency (%) HHV			
PC	35.9%	25.7%	-28.6%
Baseline IGCC	39.5%	30.5%	-22.9%
Pre-investment IGCC	39.5%	30.5%	-22.9%
CO₂ emissions (tonne/MWh_e)			
PC	0.875	0.160	-81.7%
Baseline IGCC	0.795	0.146	-81.6%
Pre-investment IGCC	0.795	0.145	-81.8%
Fuel input (billion Btu/hr)			
PC	4.39	4.39	0%
Baseline IGCC	4.43	4.43	0%
Pre-investment IGCC	4.43	4.81	+8.49%

The percentage reduction in output after retrofit is the substantially higher for PC at 28.7%, than it is for baseline IGCC at 22.9% and for pre-investment IGCC at 16.4%. Before retrofit, the thermal efficiency of PC at 35.9% is lower than that of baseline IGCC at 39.5% and pre-investment IGCC 39.5%. All three technologies are assumed to operate at a capacity factor of 90%.²⁴

²⁴ The capacity factors assumed for baseline IGCC and pre-investment IGCC in the studies were 90%. PC was assumed to have a capacity factor equal to that of the IGCC cases.

After retrofit, the thermal efficiency of PC at 25.7% is again substantially lower than those of baseline IGCC at 30.5% and pre-investment IGCC at 30.5%. The carbon emissions from all three technological options are almost the same per unit of electric output, both with and without capture.

3. Problem Formulation

Numerous factors interact in complex and non-linear ways to influence investment value. Our understanding of how all the different factors interact is limited, and our ability to concurrently analyze their impact on value is restricted by the lack of analytical tools. The thesis adopts a “problem formulation” approach to gain an insight into the most important drivers that influence coal-fired power plant investment decisions in an uncertain carbon policy environment. Initial choices and assumptions behind the technologies, cash flow variables and stochasticity, project funding, valuation approaches and retrofit flexibility are explicitly defined and structured in the problem formulation,²⁵ and the impacts of these choices on investment value are systematically explored.

For the sake of clarity, it is important to define the usage of “stochastic” and “deterministic” in this thesis. A stochastic variable is one “whose future value is uncertain”.²⁶ This includes variables that are correlated with the economy and those that are not.²⁷ On the other hand, “deterministic” variables are those whose value at any future time is known with certainty. In this thesis, stochastic variables whose uncertainties have a comparatively small impact on value are approximated as being deterministic.

²⁵ Heylighen F. (1988): Formulating the Problem of Problem-Formulation, in Cybernetics and Systems '88, Trapp R. (ed.), (Kluwer Academic Publishers, Dordrecht), p. 949-957. <http://pespmc1.vub.ac.be/Papers/Problem-Formulation.html>.

²⁶ Financial dictionary; <http://www.specialinvestor.com/terms/215.html>.

²⁷ Stochastic variables that are correlated with the economy have dynamic uncertainty associated with future expectations caused by new information about the economy coming in over time. On the other hand, the dynamic uncertainty associated with the expectations of stochastic variables not correlated with the economy is dependent on local uncertainties that evolve over time.

3.1 Problem Dimensions and Scope

The problem formulated in the thesis compares specific representative investments in different coal-fired power plant technologies in a scenario of uncertain CO₂ prices using different valuation approaches and assuming different levels of temporal decision flexibility in capture retrofits. Table 3.1 below summarizes the problem scope along the dimensions of technologies to be evaluated, cash flow parameters and the number of stochastic variables, project funding, valuation approaches and temporal flexibility in retrofit decision making.

Table 3.1: Problem Dimensions and Scope

Problem Dimension	Problem Scope
Technologies	(i) PC (ii) Baseline IGCC (iii) Pre-investment IGCC
Cash flow variables	(i) Revenues ²⁸ (ii) Upfront Investment (iii) Retrofit investment (iv) Fuel costs (v) O&M costs (vi) CO ₂ emission costs (vii) Corporate Taxes
Number of stochastic variables	One
Project funding	All equity, by well-diversified investors
Valuation approaches	(i) Discounted Cash Flow (DCF) (ii) Market Based Valuation (MBV)
Retrofit decision flexibility	(i) Predetermined decision to retrofit in a predetermined operating year (ii) Option to retrofit at the end of any operating year

The choice of technologies, valuation methodologies and retrofit decision options are comprehensive. The most cost-efficient coal-fired technologies, PC and IGCC, have

been chosen, and specific representative cases have been either selected or constructed. The retrofit decision choices for each technology include deterministic retrofits and the option to retrofit annually. Investments in these technologies and retrofits are valued using both the MBV and DCF approaches.

Some of the more restrictive assumptions that may be a concern relate to the number of stochastic cash flow variables. The complexity of investment valuation increases dramatically as the number of stochastic variables increase. The number of cash flow variables for investment valuation are limited to investment (upfront and retrofit), revenues, fuel costs, O&M costs, CO₂ emission costs and the determinants of corporate taxes, so as to keep the analysis simple. Some of these cash flow variables have significantly larger uncertainties than others do. The thesis attempts to identify these variables, and integrate their dynamic uncertainties into the valuation analysis.

The number of stochastic variables has been limited to one, so as to keep the investment analysis and tools simple. Of the cash flow variables, it can be expected that revenue (dependent on electricity price), CO₂ emission costs (dependent on CO₂ prices) and fuel costs (dependent on coal prices) are stochastic, while investment and O&M costs can be approximated to be deterministic.²⁹ Given that the thesis seeks to explore CO₂ price uncertainty, CO₂ price was the first choice for the lone stochastic variable. There were two alternatives available to deal with the other two stochastic variables – they could either be considered to be deterministic, or be made redundant to the investment analysis.

²⁸ Note that in the problem formulated, revenues are the same across all technological options and don't impact relative cost comparisons. They are, therefore, not computed. This is discussed in more detail in Section 3.1.

Revenue cash flows were made redundant to the analysis. This was done by constructing the problem such that all the technological options are required to deliver equal net electric outputs to the grid over their useful life. This means that they will have equal revenues at all times, irrespective of electricity prices. In a comparative analysis of the different technologies, revenues will not impact the analysis.

Fuel costs are dependent on market prices of coal, which are correlated to the market and also to other fossil fuels such as natural gas. However, given the restriction on the number of stochastic variables, it was decided not to consider these uncertainties and take coal prices to be deterministic. Sensitivity tests on coal prices will be conducted over a wide range to understand the impact of varying coal prices on investment value. If investment value and technology choices are found to be sensitive to coal prices in this thesis, future work on more complex two-factor stochastic cash flow models could incorporate coal price as the second stochastic factor.

Further, the plant is assumed to be constructed on an all-equity basis, by investors with well-diversified risks. Assuming perfect capital markets and absence of any interaction between investment and financing decisions, the choice of financing does not impact firm value.³⁰ Both these assumptions are not true in reality, and the choice of financing does impact firm value. However, since it is not the focus in this thesis to explore the relationship between the investment value and capital structure, the analysis was simplified by assuming all-equity financing.

²⁹ Refer to the introductory paragraph in this chapter for a description of how “stochastic” and “deterministic” are being used in this thesis.

³⁰ Modigliani-Miller Proposition I: *Principles of Corporate Finance*, Fourth Edition; Richard Brealey and Stewart Myers.

4. Cash Flow Model

For each technological option, this chapter provides the structure of the cash flow model and specific details of the cash flow variables discussed in Chapter 3. In order to value the future cash flows of a project over its useful life, it is essential to know the magnitude and timing of these cash flows and the associated risks. The cash flow model provides a framework for calculation of the expectations of deterministic cash flow variables discussed in Section 3.1. It also provides the annual CO₂ emissions for the different technologies, which is used to calculate the stochastic CO₂ emission costs. All cost numbers in this thesis are based in 2002 US\$. The details of uncertainties in the cash flows and the basis for development of discount rates will be discussed in the Chapter 6.

In building the cash flow models for the technology choices, the underlying cost structure for the three cases described in Chapter 2 were developed based on the problem formulated in Chapter 3. To derive the cost elements shown in Table 4.1, all cases were designed to have a constant net electric output (before and after capture) of 513 MW.

This was accomplished as follows:

- The capacity and costs elements of the PC case (in Table 2.2) were scaled from 462 MW to 513 MW. Note that the IGCC cases were already based on a capacity of 513 MW.
- For each technology, “new” capture capacity was assumed to be added to compensate or “make-up” for the loss in electric output due to retrofit. The cost elements for the make-up plant for each technology were derived by suitably scaling the costs of capture plants for the specific technology.

Table 4.1: Economic Comparison of PC, Baseline IGCC and Pre-investment IGCC

ECONOMIC COMPARISON
All cases at 513MW and capacity factor of 90%

Capital cost (\$ million)	Upfront Cost	Retrofit + Make-up Plant Cost	Total*
PC	579	463	1,042
Baseline IGCC	629	335	964
Pre-investment IGCC	697	224	921
Fuel Costs (\$ million: at \$1.1/MMbtu)	Before Retrofit	After Retrofit	Increase (%)
PC	42	59	40.0%
Baseline IGCC	38	50	29.7%
Pre-investment IGCC	38	50	29.7%
Operations and Maintenance Costs (\$ million)	Before Retrofit	After Retrofit	Increase (%)
PC	20	34	70.0%
Baseline IGCC	27	39	43.3%
Pre-investment IGCC	29	37	24.7%

* Time value of money is not considered

It can be derived from the information in Table 4.1 that the capital cost of building a 513MW PC plant is 8% lower than building a 513MW baseline IGCC plant, whose capital cost is 10% lower than building a 513MW pre-investment IGCC plant. The costs for retrofit and building additional capacity to compensate for the capacity reduction show substantially different trends. These costs for PC are 38% higher than those for baseline IGCC, which are 50% higher than those for pre-investment IGCC. Before capture, the fuel cost for PC is 10% higher than those of baseline IGCC and pre-investment IGCC. After capture, fuel cost of PC is 19% higher than those of baseline IGCC and pre-investment IGCC. The operations and maintenance (O&M) cost for PC are lower than that of baseline IGCC and pre-investment IGCC before capture, and also after capture. Before capture, O&M cost of PC are 25% lower than that of baseline IGCC, which in turn is 9% lower than that of pre-investment IGCC. After capture, O&M

cost of PC are 11% lower than those of baseline IGCC, which are 5% higher than that of pre-investment IGCC.

The details provided in Table 4.1 can be used to construct cash flow models for these three technologies. Usually, asset cash flows before taxes are determined using Equation 4.1.

$$\text{Net Cash Flow} = \text{Operating Cash Revenue} - \text{Operating Cash Cost} - \text{Investment} \quad (4.1)$$

“Investment” refers to capital investment to procure assets, and “operating cash revenue” and “operating cost” refer to cash flows that occur in the normal operations of the asset. In Equation 4.1, all variables are assumed to have positive values, and the sign preceding it decides the contribution of the variable to the cash flow. Based on the problem formulated in the thesis in Section 3.1, we don’t need to compute operating revenues in order to compare the different technological options. For our purposes, it is adequate to calculate:

$$\text{Cash Flow} = - \text{Operating Cash Costs} - \text{Investments} \quad (4.2)$$

Since the cash flow for the purposes of the thesis will always be negative, it is simpler to use the “cost cash flow before taxes”, which is the sum of investments and operating cash costs.

$$\text{Cost Cash Flow Before Taxes} = \text{Investment} + \text{Operating Cash Costs} \quad (4.3)$$

Equation 4.4 is used to calculate the after-tax cost cash flow. The major operating cash costs, for our purposes, are fuel costs, O&M costs and CO₂ emission costs. The tax shield represents the tax impacts of these operating cash flows and depreciation.³¹

$$\text{Cost Cash Flow After Taxes} = \text{Investment} + (\text{Fuel costs} + \text{O \& M costs} + \text{CO}_2 \text{ emission costs} - \text{Tax shield}) \quad (4.4)$$

The methodology for calculating the different components of Equation 4.4 above, and the results for the specific cases chosen are described below.³²

4.1 Investments

The investment cash outflow assumes a non-zero value in only two years in the 40 year useful life of the plants:

- (i) In 2010 (time = 0), where investment is the upfront capital spent in setting up the technology.
- (ii) In the year of retrofit, which is between 2010 and 2050 ($0 < t \leq 40$), where investment is the sum of the capital spent on retrofitting the existing plant and constructing the make-up plant.³³

³¹ Accelerated depreciation at 30% per year is assumed for the purposes of tax calculation.

³² Infra Chapter 2.

³³ Infra Chapter 2, Chapter 3.

Table 4.1 provides information on the investment cash flows for the three specific cases, assuming a constant net electric output of 513MW through the useful life at a 90% capacity factor.

4.2 Fuel

Fuel costs are calculated as the product of fuel price per unit of energy and the energy consumed by the operating facility. The energy consumed per year is the product of the net heat rate of the facility (i.e., the fuel energy consumed per unit net electric output) and the net electric output. Combining the two, we get:

$$\text{Fuel costs} = \text{Fuel price per unit of energy} * \text{Net heat rate} * \text{Net electric output} \quad (4.5)$$

In our case, the following units are used for the above variables.

Fuel costs	\$/year
Fuel price per unit of energy	\$/ million Btu
Net heat rate	Btu/kWh
Net electric output	MWh/year

The fuel price is taken to be constant over the useful life of the assets at \$1.1/million Btu, and results are sensitivity tested at \$1.5/ million Btu and \$2/ million Btu. The purpose of the wide range of sensitivities is to attempt to explore the implications of omitting fuel price as a stochastic variable.

The net heat rate is a function of whether the plant has been retrofit or not. There is a marked increase in the net heat rate after retrofit for all three cases. In the three cases

considered, the net electric output is constant at 4.04×10^6 MWh/year (513 MW at a capacity factor of 90%) for the useful life of the plants.

A summary of the annual fuel costs for the three different cases for different coal price sensitivities are summarized in Table 4.2.

Table 4.2: Annual Fuel Costs for the Three Technologies at different Fuel Prices

	Fuel Price (\$/million Btu)	Before Retrofit		After Retrofit	
		Net heat rate (Btu/KWh)	Fuel cost (\$ million/yr)	Net heat rate (Btu/KWh)	Fuel cost (\$ million/yr)
PC	1.1	9,501	42	13,301	59
Baseline IGCC	1.1	8,637	38	11,204	50
Pre-investment IGCC	1.1	8,637	38	11,205	50
PC	1.5	9,501	58	13,301	81
Baseline IGCC	1.5	8,637	52	11,204	68
Pre-investment IGCC	1.5	8,637	52	11,205	68
PC	2.0	9,501	77	13,301	108
Baseline IGCC	2.0	8,637	70	11,204	91
Pre-investment IGCC	2.0	8,637	70	11,205	91

It can be seen from Table 4.2 that the fuel cost differential between the PC and the IGCC technologies increases with increasing fuel prices, both before and after retrofit. The difference in fuel costs between the before retrofit and after retrofit modes for each technology also increases with increasing in fuel prices.

4.3 O&M Costs

Fixed and variable O&M costs have been combined together as one O&M cost. The O&M cost for a plant is dependent on whether the operating facility has been retrofitted or not, increasing substantially after retrofit as discussed in Chapter 2. A

summary of the O&M costs for the three cases before and after retrofit are summarized in Table 4.3.

Table 4.3: Annual O&M Costs for the Three Technologies

	Before Retrofit	After Retrofit
	\$ million/year	\$ million/year
PC	20.2	34.4
Baseline IGCC	26.9	38.5
Pre-investment IGCC	29.5	36.7

4.4 CO₂ Emission Costs

CO₂ emission costs are a product of the mass of CO₂ emitted by the operating facility and the market price of emissions. The mass of CO₂ emitted is a product of the mass of CO₂ emitted per unit net electric output and the net electric output. A simplifying assumption has been made that each technology uses the same type of coal. The numerical values for the CO₂ emitted per unit net electric output, before and after retrofit, have been extracted from the specific studies the cases were selected from. Assuming the same coal type for all three cases means that the variation in CO₂ emitted is directly proportional to the heat rates. The market price of CO₂ emitted is assumed to be a stochastic function of time as discussed in detail in Chapter 5.

Unlike other variables we have dealt with earlier, it will not be possible to put down a precise number for CO₂ emission costs in the before-retrofit and after-retrofit mode. Rather, an equation that has CO₂ price as an independent variable will be required to describe CO₂ emission costs.

$$\text{CO}_2 \text{ emission costs} = \text{CO}_2 \text{ price} * \text{CO}_2 \text{ mass emitted per unit net electric output} \\ * \text{Net electric output}$$

In the calculation of CO₂ emission costs, the following units are used for the different variables.

CO ₂ emission cost	\$/year
CO ₂ emission per unit net electric output	t/MWh
Net electric output	MWh/year
CO ₂ price	\$/t

A summary of the CO₂ emissions for the three cases is summarized in Table 4.4.

Table 4.4: CO₂ Emissions for the Three Technologies Before and After Retrofit

	CO ₂ Emissions Before Retrofit		CO ₂ Emissions After Retrofit	
	t/MWh	Mt/year	t/MWh	Mt/year
PC	0.875	3.537	0.160	0.649
Baseline IGCC	0.795	3.215	0.146	0.590
Pre-investment IGCC	0.795	3.215	0.145	0.586

The CO₂ emission costs (\$ million/year) are calculated by multiplying the appropriate CO₂ emissions per year (Mt/year) from Table 4.3 by the stochastic CO₂ price (\$/t) in that year.

4.5 Taxes

Taxes arising from costs are calculated using Equation 4.6.

$$\text{Tax shield} = \text{Marginal tax rate} * (\text{Fuel costs} + \text{O \& M costs} + \text{CO}_2 \text{ emission costs} + \text{Depreciation}) \quad (4.6)$$

All the terms in the equation above, other than depreciation have already been discussed. Deprecation is computed on the upfront investment and retrofit+make-up plant investments using a 30% accelerated depreciation schedule. Depreciation of the retrofit + make-up plant takes into account the timing of the retrofit decision. A 2.5% per year inflation adjustment is assumed when calculating depreciation, so as to reflect the constant dollar assumption made for all other cash flow variables discussed. The marginal tax rate is assumed to be 40%.

5. Carbon Dioxide Expert Price Elicitation and Stochastic Price Model

The current value of a coal-fired power plant is dependent on the uncertainty in CO₂ prices through its operating life. The firm investing in such a power plant has to consider future CO₂ prices and their uncertainty before making an investment, despite not having any price history to inform such predictions. There is no alternative but to use expert opinion of future price uncertainties in building CO₂ price models to use in quantitative investment valuation processes.

For the purposes of the thesis, estimates of aspects of the distribution of future CO₂ prices for the US power sector for the period 2010 to 2050, conditioned on 2005, were elicited from three experts in energy and environmental economics –Dr. Denny Ellerman,³⁴ Dr. Henry D. Jacoby³⁵ and Dr. John Reilly.³⁶ They are hereafter referred to as Subjects 1, 2 and 3. Three quantitative CO₂ price models were then constructed to match the information elicited from the subjects.

Section 5.1 describes the expert elicitation process and the results of the elicitation. Section 5.2 describes the theory behind the form and assumptions of the CO₂ price model, and parameters of the price models constructed for each subject.

³⁴ Executive Director, Center for Energy and Environmental Policy Research, MIT.

³⁵ Co-Director of the Joint Program on the Science and Policy of Global Change, MIT.

³⁶ Associate Director of Research, Joint Program on the Science and Policy of Global Change, MIT.

5.1 CO₂ Price Elicitation

The price elicitation process asked experts to give their current estimates of the term structure of CO₂ price medians and 80% confidence intervals from 2010 to 2050.³⁷ The protocol used was adapted from earlier research on expert elicitation on factors contributing to the cost of climate policies at the Joint Program on the Science and Policy of Global Change at MIT.³⁸ A standard protocol was followed from each subject. The sequential steps are described below.

- Introduction: An overview was provided on the research being conducted. The concepts of “capture capability” and “capture readiness”³⁹ of different coal-fired power plant technological options were discussed. The impact of future CO₂ prices and uncertainty on economically optimal technology choice was explained. Permission was sought for using their estimates of future CO₂ uncertainty in the economic analysis of these technological options. The influence of carbon policy on the CO₂ prices to be borne by the US power sector was brought up. The different CO₂ price possibilities discussed were: (i) a global price applicable to all US economic sectors, including the power sector. (ii) a uniform price, specific to the US across all sectors, including the power sector (ii) a specific price for the US power sector only.
- Anchoring: In order to provide the subjects with a reference point they could anchor their estimates on, US carbon emissions projections for different carbon

³⁷ Section 5.2 provides a methodology for resolution of dynamic uncertainty.

³⁸ Paul F. Cossa (2004). *Uncertainty Analysis of the Cost of Climate Policies* (unpublished S.M. thesis, Massachusetts Institute of Technology).

³⁹ Infra Chapter 1.

price paths based on EPPA⁴⁰ model runs were provided. It was clarified that the model assumes a common global price for carbon across all sectors of the economy. Four different US carbon emissions paths for four carbon prices paths were provided based on EPPA runs.⁴¹ The carbon price paths were applied to the model starting 2005, when the US carbon emissions were estimated at 1.67 billion tonnes. The results of the carbon emissions paths for the four carbon price scenarios are summarized below:

- (i) Zero carbon price scenario: This resulted in the carbon emissions growing from 1.85 billion tonnes in 2010 to 3.61 billion tonnes in 2050.
- (ii) Low carbon price scenario: In this path, the carbon price grew from \$19/tonne in 2010 to \$100/tonne in 2050, at 4% per year. The carbon emissions grew from 1.76 billion tonnes in 2010 to 2.90 billion tonnes in 2050.
- (iii) Medium carbon price scenario: In this scenario, the carbon price grew from \$37/tonne in 2010 to \$200/tonne in 2050, at 4% per year. The carbon emissions grew continuously from 1.69 billion tonnes in 2010 to 2.50 billion tonnes in 2050.
- (iv) High carbon price scenario: The carbon price in this scenario grew from \$75/tonne in 2010 to \$400/tonne in 2050, at 4% per year. The carbon emissions grew from 1.59 billion tonnes in 2010 to 1.98 billion tonnes in 2040, after which it declined to 1.87 billion tonnes in 2050.

⁴⁰ Emissions Prediction and Policy Analysis (EPPA) model, developed by the Joint Program on the Science and Policy of Global Change, MIT.

⁴¹ It should be noted that the prices were specified in \$/tonne of carbon and not in \$/tonne of CO₂, and emissions were specified in million tonnes of carbon.

- Elicitation: The “simple” windows⁴² approach was provided as a way to elicit information about the price distributions, where the subject was asked to provide the median, 90th and 10th fractiles of carbon prices in 2015, 2035 and 2050. The 90th and the 10th fractiles were elicited prior to the medians. The subjects were then asked for their consent in fitting a smooth curve to fit these points, and to extrapolate their data back to 2010.
- Checking the Output: The results from the quantitative CO₂ models, based on the expert elicitation were presented to the subject for their affirmation. The results of the price elicitation are presented in Table 5.1.

Table 5.1: Results from the carbon price elicitation process (\$/t carbon)⁴³

Expert 1			
	10th Fractile	Median	90th Fractile
2015	10	40	75
2035	25	90	150
2050	50	150	250

Expert 2			
	10th Fractile	Median	90th Fractile
2015	5	20	50
2035	20	60	200
2050	30	100	300

Expert 3			
	10th Fractile	Median	90th Fractile
2015	0	3	100
2035	10	100	500
2050	100	300	1000

⁴² David Laughton (1988). “Financial Analysis Methods for the Resource Allocation Process in Organizations: The Oil Field Development Decision.” MIT Energy Laboratory Working Paper Series MIT-EL-88-011WP.

⁴³ \$/t carbon can be converted to \$/t CO₂ by dividing by 3.67.

5.2 Quantitative Stochastic CO₂ Price Model⁴⁴

The CO₂ price process is modeled as an evolving structure of price expectations over time. Table 5.2 below describes an illustration of this structure for three periods – the index “s” marks the movement of an investor through time, and “t” represents “future times” for which the investor is interested in finding out CO₂ prices.⁴⁵ It can be seen that as the investor reaches a particular “s”, uncertainty in the price for that time gets resolved and a new term structure of future expected prices gets created.

Table 5.2: Illustration of the Price Process

Conditioning time (s)	Expected prices at future times (t)			
	0	1	2	3
0	$E_0(P_0)=P_0$	$E_0(P_1)$	$E_0(P_2)$	$E_0(P_3)$
1		$E_1(P_1)=P_1$	$E_1(P_2)$	$E_1(P_3)$
2			$E_2(P_2)=P_2$	$E_2(P_3)$
3				$E_3(P_3)=P_3$

In a more general case, as the index “s” moves from “s” to “s+ds”, new information is received that: (i) resolves the final bit of price uncertainty during the period of time s+ds (ii) results in a new term structure of future price expectations from “s+ds”. The model of price expectations is based on the approximation that the most

⁴⁴ This section summarizes one methodology used to formulate uncertain prices. See David G. Laughton and Henry D. Jacoby (1992). “Project Duration, Output Price Reversion and Project Value”. Institute for Financial Research, University of Alberta Working Paper No. 3-91.

⁴⁵ In the actual model, the index “s” starts at 2010 (time=0 years) and moves to 2050 (time=40 years). “t” represents the time, starting from s and going through till 2050 where the stochastic prices are to be analyzed.

recent revision in the expectation of the “current” price provides all of the information needed to determine a revision of future price expectations.

For each period, s to $s+ds$, the revision of expectations for all future times is determined by a single independently distributed normal random variable, dz_s which has a mean of 0 and variance of ds . Based on this model, dz_s represents information coming in the period ds that revises the price expectation at $s+ds$. The revision of price expectation for $t > s$ is modeled based on normalized information, dz_s , and a volatility parameter $\sigma_{s,t}$.

In this model, the change in price expectation at time t , where $t > s$ as the investor moves from s to $s+ds$ is formulated as:

$$d_s E(P_t) = E_s(P_t) \sigma_{s,t} dz_s \quad (5.1)$$

The volatility parameter $\sigma_{s,t}$ can be viewed as an influence function that captures the information arriving at time s that influences expectations for all $t > s$. In commodity markets that are subject to short-term shocks and long-term equilibrating forces, the future impact of new information decays over time. As a result, $\sigma_{s,t}$ decreases as t increases.⁴⁶ The influence of information at a particular s is modeled to be exponentially decaying over time, with a half life of H .

$$\sigma_{s,t} = \sigma_s e^{-\gamma(t-s)}, \quad \text{where, } \gamma = \frac{\ln 2}{H} \quad (5.2)$$

The model for price expectation reduces to:

$$d_s E(P_t) = E_s(P_t) \sigma_{s,t} e^{-\gamma(t-s)} dz_s \quad (5.3)$$

where, σ_s is the short -term volatility at time s.

Previous work done on this price model shows that it is easier to work with medians rather than expected prices.⁴⁷ Prices that evolve according to Equation 5.3 are distributed according to a joint log-normal distribution.⁴⁸ Therefore, the term structure of median prices can be expressed in terms of the term structure of expected prices as follows:

$$M_s(P_t) = E_s(P_t) e^{-0.5 \text{var}_{s,t}} \quad (5.4)$$

where $\text{var}_{s,t}$ refers to the variance at time s of natural logarithm of the price at t.

The corresponding process for price itself, based on the above formulation is:

$$d_t P = \left[\frac{\partial_t M_0(P_t)}{M_0(P_t)} + \frac{1}{2} \sigma_t^2 - \gamma \ln \left(\frac{P_t}{M_0(P_t)} \right) \right] P_t dt + \sigma_t P_t dz_t \quad (5.5)$$

In the above equation:

P_t = price at time t

$M_0(P_t)$ = Median price at time t conditioned on $s=0$

σ_t = $\sigma_{t,t}$, which is the short term volatility at time t conditioned on $s=t$

γ = $\ln 2/H$, where H is the half life of forecast volatilities.

Two observations can be made from the above equation:

- (i) The contemporaneous price is a sufficient state variable for the price model.

⁴⁶ David G. Laughton and Henry D. Jacoby (1992). "Project Duration, Output Price Reversion and Project Value". Institute for Financial Research, University of Alberta Working Paper No. 3-91.

⁴⁷ Ibid.

⁴⁸ David Laughton (1988). "Financial Analysis Methods for the Resource Allocation Process in Organizations: The Oil Field Development Decision." MIT Energy Laboratory Working Paper Series MIT-EL-88-011WP.

- (ii) There is a price reversion stemming from the $-\gamma \ln\left(\frac{P_t}{M_0(P_t)}\right)$ term in the expected price change, which is large and negative when the price is large and large and positive when the price is small. Figure 5.5 provides an illustration of the process of CO₂ price reversion using Subject 3's price model. When a price of \$50/t CO₂ is realized in year 2015, the median, 90th and 10th fractile conditioned on this 2015 price state revert back to median, 90th and 10th fractile CO₂ prices path for 2010 to 2050 based on the curves fitted using expert elicitation data. Future conditional median prices derived from Equation 5.5 (see Equation 5.6) also reveal the reversion process at work.⁴⁹

$$M_s(P_t / P_s = P) = M_0(P_t) \left(\frac{P}{M_0(P_s)} \right)^{e^{-\gamma(t-s)}} \quad (5.6)$$

The next step is to convert the data elicited from each of the three subjects to fit a model of the form shown in Equation 5.5. As can be seen from Equation 5.5, the factors that need to be defined to arrive at the price model are:

- (i) The current term structure of price medians for all years, $M_0(P_t)$.
- (ii) Short term volatilities for all years (σ_t).
- (iii) γ , which is indirectly defined by the half-life (H) of volatilities.

The information elicited from each subject was fitted by trial-and-error to a model that helped derive the median prices from 2010 to 2050 conditioned on the current 2010 price median, and the 90th and 10th quartiles based on magnitudes and half-lives of

⁴⁹ David G. Laughton and Henry D. Jacoby (1992). "Project Duration, Output Price Reversion and Project

volatilities. The median curve was fitted from 2010 to 2050 through the data points obtained from the experts for 2015, 2035 and 2050. The annual volatilities were adjusted manually assuming at a constant half life H of 4 years⁵⁰, so that the 90th and 10th fractile curves fitted well with the elicited 90th and 10th fractile prices. The annual volatilities used for the three expert price models are shown in Figure 5.4.

These fitted curves were shown to each subject, and they confirmed that they were satisfied with the way the model reflected their views. The median, 90th and 10th fractile term price structures for the three subjects are shown in Figures 5.1, 5.2 and 5.3. The median, 10th and 90th fractiles of CO₂ prices for the 3 subjects in 2010 is shown in Table 5.3 below.

Table 5.3: 2010 CO₂ Prices (\$/t) for the Three Subjects

	Subject 1	Subject 2	Subject 3
10 th Fractile	0.45	0.23	0
Median	1.82	0.91	0.14
90 th Fractile	3.41	2.27	4.55

A more complete price elicitation procedure on CO₂ prices should focus on elicitation of the following additional information:

- (i) Median, 90th and 10th fractiles of CO₂ prices in the year of investment (2010), in addition to the years in which prices were elicited.

Value”. Institute for Financial Research, University of Alberta Working Paper No. 3-91.

⁵⁰ This value was assumed by David Laughton et al, for CO₂ prices. See David Laughton, Rick Hyndman, Andrew Weaver, Nathan Gillett, Mort Webster, Myles Allen, Jonathan Koehler (2003). “A Real Options Analysis of a GHG Sequestration Project”. (Unpublished manuscript, on file with author).

- (ii) H values, through the elicitation of prices that indicates the experts view of how uncertainty is dynamically resolved.
- (iii) Estimation of correlation between CO₂ prices and movement in the economy. Chapter 6 discusses the use of this correlation to calculate the price of risk for CO₂.

Based on the CO₂ price models constructed, the following initial observations can be made. Subject 1 has the lowest uncertainty in price, while Subject 3 has the highest uncertainty. Subject 2 has an uncertainty level which is between Subject 1's and Subject 3's, but closer to Subject 1's. In terms of median prices, Subject 3 has a low median price to start with, but increases very rapidly in the later years. On the other hand, Subjects 1 and 2 have related stably rising median prices, with Subject 1's median price being marginally higher than Subject 2's from 2010 to 2050.

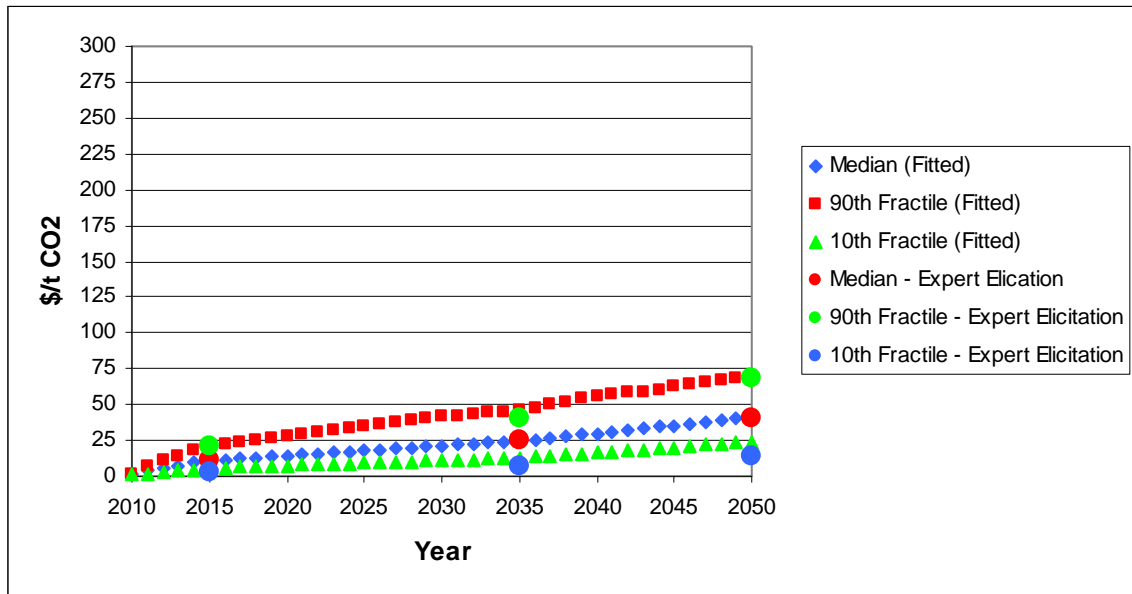

Figure 5.1: Subject 1: Prices elicited and curve fitted by the model

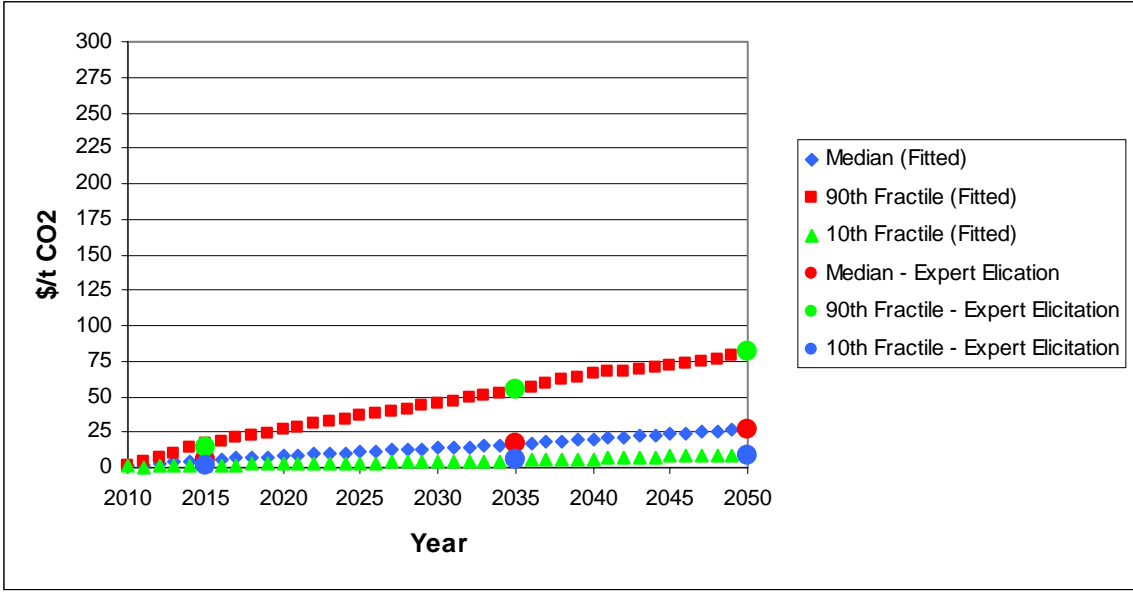

Figure 5.2: Subject 2: Prices elicited and curve fitted by the model

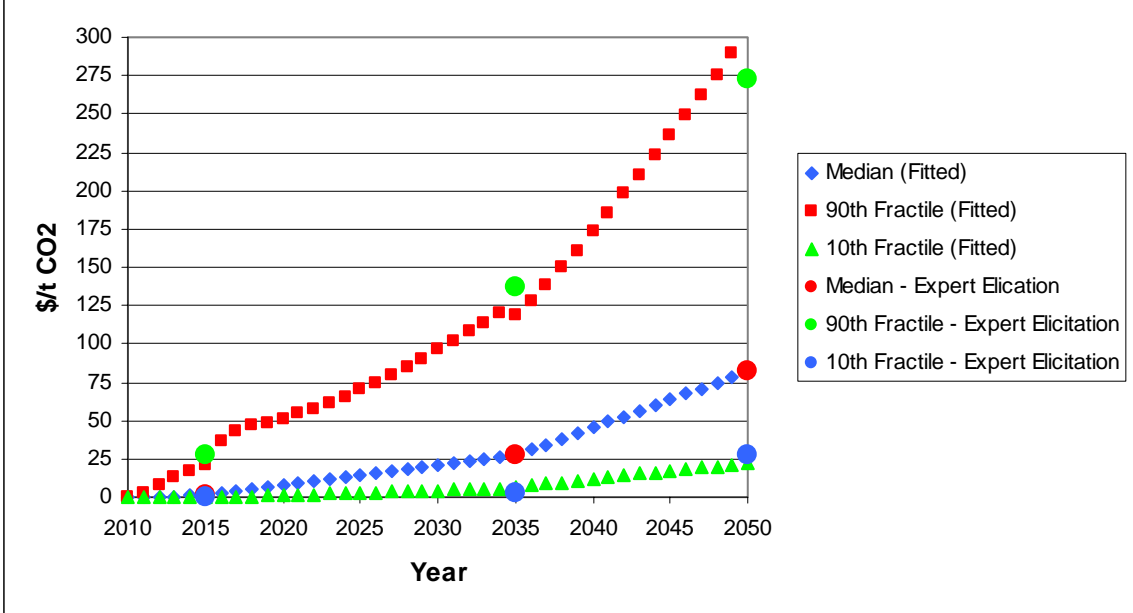

Figure 5.3: Subject 3: Prices elicited and curve fitted by the model

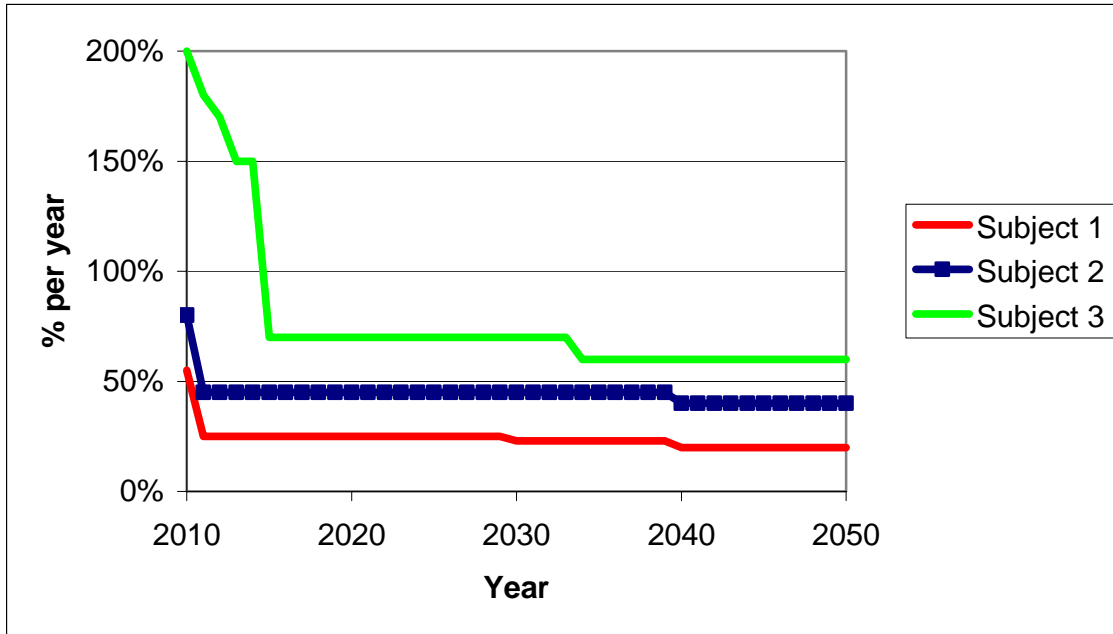

Figure 5.4: Annual volatilities for the CO₂ price models for the three experts. These volatilities are chosen through a trial-and-error process so as to fit (using H=4 years) the data elicited from the experts.

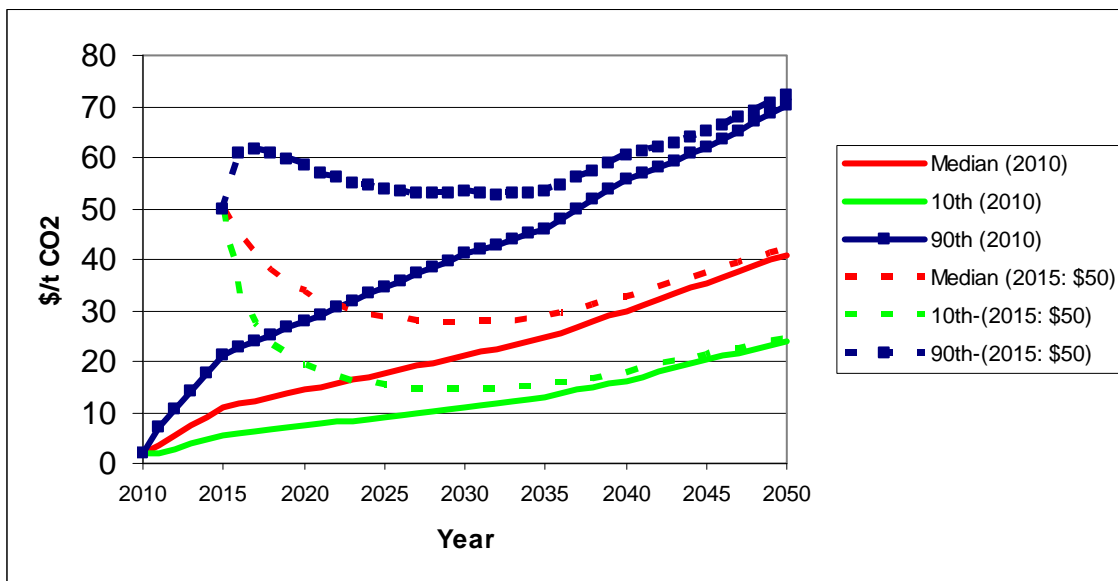

Figure 5.5: Shows the process of CO₂ price reversion in Subject 3's price scenario. If the price in 2015 ends up being \$50/t CO₂, the median, 90th and 10th fractiles revert to the median, 90th and 10th fractiles conditioned on 2010.

6. Valuation Methodology

This chapter discusses the different approaches to valuing cash flows from the stochastic cash flow model set up in Chapters 4 and 5. The methodologies presented in this chapter take the perspective of a financial market participant with well-diversified risks operating in a deep financial market. Such a participant values uncertainties associated with non-diversifiable risks, but does not directly value uncertainties associated with diversifiable risks.

Section 6.1 provides the taxonomy of asset valuation methods that have been used or considered for use in the energy industry. Section 6.2 provides a discussion on the rationale for using the Market Based Value (MBV) approach, combined with flexible retrofit decision making, as the appropriate approach to value the technological options. Section 6.3 discusses the different valuation approaches applicable to the problem scope outlined in Table 3.1. Section 6.4 and Section 6.5 develop answers to research questions (i) and (ii) (see Chapter 1) respectively, concerning temporal value of flexibility in retrofit decision making and impact of choice of valuation method on technology choice.

6.1 The Banff Taxonomy of Asset Valuation Methods

In evaluating the viability of an investment in an asset, the objective is to find out the current value of future cash flows. Two characteristics of cash flows determine value:

- (a) Timing
- (b) Uncertainty

While the concept of timing of cash flow and its impact on current value is well understood, the impact of uncertainty of cash flow on value is not that well understood. The Banff taxonomy⁵¹ (Figure 6.1) provides a way of organizing valuation methods by the way cash flow uncertainty is modeled and valued.

		Valuing Uncertainty	
		Asset Cash Flow	At source
Modeling uncertainty	Dynamic Quantitative	Complete DCF Scenario Trees	Real Options Analysis
	Static Quantitative	DCF Simulation	Risk Adjusted State Pricing
	Qualitative	DCF Scenarios	Risk discounting with forward prices

Figure 6.1: The Banff Taxonomy of Asset Valuation Methods. Valuation methods are categorized by the way cash flow uncertainties are (i) Modeled, and (ii) Valued. The valuation methods that are highlighted (in bold) are explored in this thesis.

6.1.1 Modeling Uncertainty

Uncertainties in cash flows are often modeled in a qualitative fashion, as a series of scenarios that cover the possible range of cash flows without paying attention to their probabilities of occurrence. Such scenarios do not capture the dynamic changes in uncertainty as new information arrives. Spreadsheet models can be used to carry out the investment analysis in such situations.

Quantitative models of uncertainty generate explicit probabilistic cash flows. Such probabilistic scenario generation may be static, or dynamic if uncertainties are

⁵¹ David Laughton, R.B. Bratvold, S.H. Begg, J.M. Campbell Jr. (2004). “Development as a Continuation

dynamically resolved over time. A pictographic representation of scenario generation for the different methods of modeling uncertainty is shown in the Figure 6.2. It is used when one-time decisions are to be made based on the cash flow scenario realized.

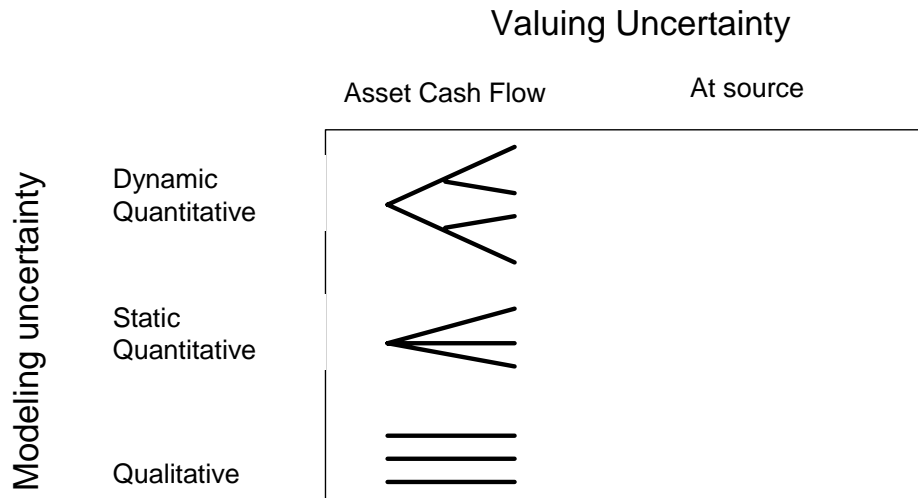

Figure 6.2: Pictographic representation of scenario generation for based on various approaches to modeling cash flow uncertainty

Dynamic quantitative modeling of uncertainty involves building scenario trees to reflect the uncertainties of the underlying uncertain variables in the cash flow. It is required when decision making is dynamic and dependent at each time on the particular scenario of the underlying uncertain cash flow variables that is realized.

6.1.2 Valuing Uncertainty

The impact of uncertainty of cash flow could be valued using two approaches:

- (i) By taking the expectation of the uncertain cash flows, and discounting them for time and risk at the weighted average cost of capital.⁵²

of Appraisal by Other Means". (Unpublished manuscript, on file with author)

⁵² The weighted average cost of capital could be at the corporate or project levels.

- (ii) By taking the uncertain cash flow variables, adjusting them for risk due to the uncertainty caused by correlation to the economy, to form a risk-adjusted probability distribution, then computing the expectation of the uncertain cash-flows, with respect to this risk-adjusted distribution, and finally discounting these risk-adjusted cash-flow expectations for time at the risk-free rate.

Method (i) is called the Discounted Cash Flow (DCF) approach, while (ii) is the called the Market Based Valuation (MBV) approach. MBV estimations of value are based on "comparables" approach to valuation, which states that two assets with the same characteristics, in our case the same cash-flow patterns, will have the same value in markets in which trading can take place freely. We make this approximation. The method we use is outlined in Section 6.2.

In calculating values of cash flows, the DCF approach discounts all components of cash flow, at all years, using the same and constant cost of capital. In this method, cash flow components with no uncertainty get discounted at the same levels as do cash flows that are uncertain.

The MBV approach, on the other hand, implicitly discounts different aspects of cash-flow stream at different rates, and, in particular discounts risk-free cash-flows at the risk free rate.

The approach used by the MBV and DCF valuation methods is illustrated using Equations 6.1, 6.2 and 6.3 below.

$$\text{MBV: Cash flow value} = \text{CEQ} (CF_t) * \exp(-r_f * t) \quad (6.1)$$

where,

CF is the cash flow at any time t.

CEQ (CF) is the certainty equivalent or risk-adjusted expectation of the cash flow CF

r_f is the risk-free rate.

The method for calculation of CEQ(CF)⁵³ is shown schematically in Equation 6.2.

$$CEQ(CF_t) = E(CF) * \exp(-P_{risk} * \sigma_{CF}) \quad (6.2)$$

where,

E(CF) is the expectation of the Cash Flow.

P_{risk} = Price of risk⁵⁴, and is equal to risk discounting per unit volatility in the cash flow.

In this thesis, the market price of risk for CO₂ emissions costs is taken as 0.4.⁵⁵

$$DCF: \text{Cash flow value} = E(CF) * \exp(-r * t) \quad (6.3)$$

r = Weighted average cost of capital for the project

⁵³ David Laughton (1998). "The Potential for Use of Modern Asset Pricing Methods for Upstream Petroleum Project Evaluation: Introductory Remarks". The Energy Journal, Vol 19, No.1

⁵⁴ Based on the Capital Asset Pricing Model, which is a model that is used to price risk, the price of risk associated with a commodity price is defined in terms of the correlation of the commodity price to the overall financial market return, the expectation of market risk premium and market volatility according to the equation below:

$$\text{Price of Risk} = \frac{\text{Correlation (Commodity price, market return)} * E(\text{Market Risk Premium})}{\text{Market Volatility}}$$

⁵⁵ David Laughton, Rick Hyndman, Andrew Weaver, Nathan Gillett, Mort Webster, Myles Allen, Jonathan Koehler (2003). "A Real Options Analysis of a GHG Sequestration Project". (Unpublished manuscript, on file with author)

It is possible but highly improbable that the cash flow values using the two methods end up being the same. Some of the values used for the variables in Equations 6.1, 6.2 and 6.3 are given in Table 6.1.⁵

Table 6.1: Values for Cash Flow Valuation Parameters

Parameter	Value
P_{risk} for CO ₂ Price ⁵⁶ (used to compute CO ₂ emission costs)	0.40 in annual terms
r	10% per year
r_f	3% per year

6.2 Preferred Approach to Valuation

As can be seen from the preceding discussion, moving upwards along the modeling axis (Figure 6.3) is essential to understand how uncertainty gets resolved on a dynamic basis. Dynamic quantitative modeling of uncertainty is essential when decision making is dynamic.

One of the objectives in the thesis is to value investments where an option exists to retrofit CO₂ capture equipment at any time during the useful life of the asset. Such an option is referred to in this thesis as an “American” option.⁵⁷ CO₂ prices have to be modeled using a dynamic quantitative approach to value such an option.⁵⁸

⁵⁶ Only CO₂ price is assumed to be stochastic, and therefore P_{risk} is required only for CO₂ price. Other costs are taken to be deterministic.

⁵⁷ It is not strictly an American option in this case, because it is assumed that the option can be exercised at the end of every operating year, and not any time in between.

⁵⁸ Such a stochastic CO₂ price model was developed in Chapter 5.

It is a fundamental proposition of this thesis that MBV is superior to DCF as a valuation approach. Section 6.1.2 also describes the inherent deficiency of the DCF approach, in that it discounts cash flows that are:

- (i) deterministic with a discount rate that provides for some uncertainty
- (ii) stochastic with a discount rate that does not adequately provide for the uncertainty.

The MBV approach seeks to correct these flaws. Based on the above discussion, “real options analysis” (Figure 6.3) is the preferred valuation approach, and will be used to evaluate different technologies.

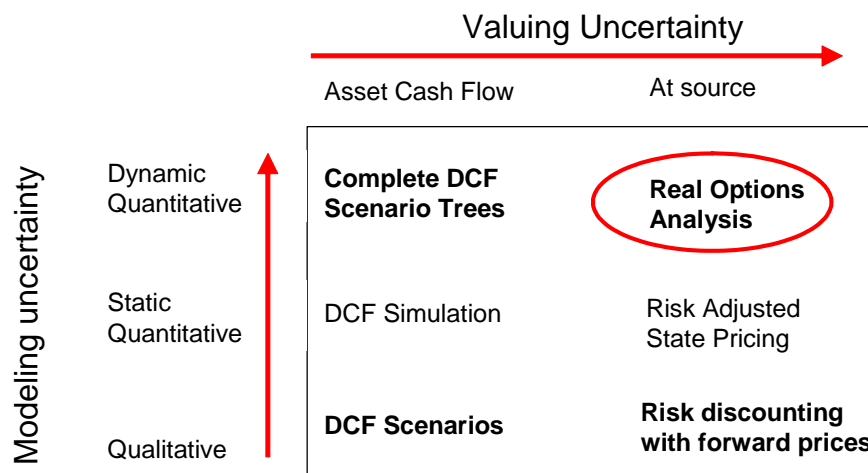

Figure 6.3: Preferred Valuation Approach

The valuation approaches for all the cases⁵⁹ (overlaid on the Banff taxonomy in Figure 6.4) defined in the problem scope in Table 3.1 will be discussed in Section 6.3, so as to demonstrate the value of retrofit flexibility and the impact of inaccurate valuation by DCF.

⁵⁹ In terms of retrofit flexibility and valuation (DCF and MBV)

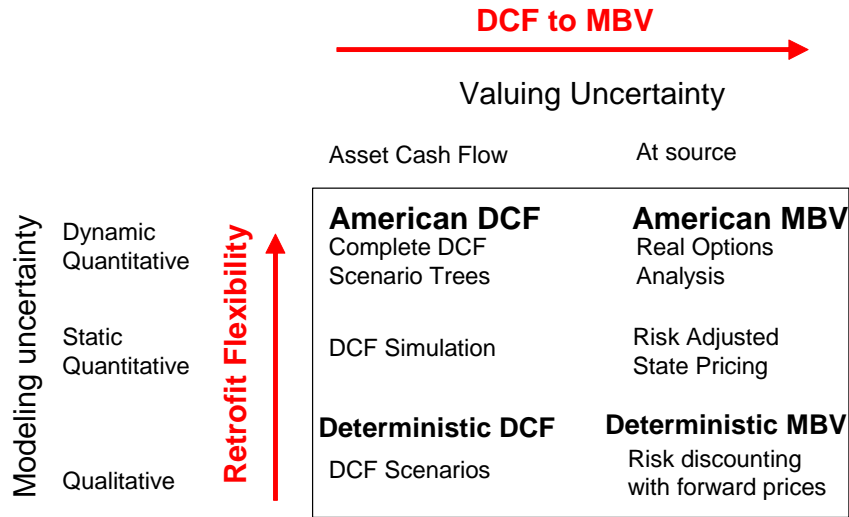

Figure 6.4: The cases for analysis formulated in Section 3.1 are overlaid on the Banff Taxonomy, in bold font. “American” refers to the flexibility to retrofit in any year, while “Deterministic” refers to an upfront commitment to retrofit in a given year.

6.3 Illustration of the Valuation Methods Applied

To prepare for analysis of the more complex cases to be explored below, Section 6.3.1 and 6.3.2 will summarize the details⁶⁰ of the methods and explain the application of all the valuation methods in bold font in Figure 6.4, in the context of a single project valuation shown in Table 6.2.

⁶⁰ For a detailed description of the theoretical foundation behind these valuation approaches, please refer to David Laughton, Jacob S. Sagi, Michael R. Samis (2000). “Modern Asset Pricing and Evaluation in the Energy Industry”. Western Centre for Economic Research, Bulletin 56.

Table 6.2: Specific Case for Illustration

CO ₂ Price Model	Subject 1 ⁶¹
Cash Flow Model	Pre-investment IGCC ⁶²
Retrofit flexibility	Deterministic and American Option
Valuation methodology	DCF and MBV
Fuel Price	\$1.1/million Btu

6.3.1 *Deterministic DCF and MBV cases using DCF Scenarios and Risk Discounting with Forward Prices*

As discussed in Chapter 4, for the purposes of comparing different technologies for the problem formulated in this thesis, it is adequate to compute the cost NPV using the different valuation approaches. The cash flow (CF) model used for this purpose is linear⁶³ and of the form:

$$\text{CF (at time } t \text{ before retrofit)} = a_{1,t} + b_{1,t} * P_{\text{CO}_2,t}$$

$$\text{CF (at time } t \text{ after retrofit at } T) = a_{2,t,T} + b_{2,t,T} * P_{\text{CO}_2,t}$$

$a_{1,t}$ and $a_{2,t,T}$ represents all the post tax costs in year t , other than the CO₂ emission costs.

$b_{1,t}$ and $b_{2,t,T}$ represents the after-tax mass of CO₂ emissions⁶⁴ in year t .

$P_{\text{CO}_2,t}$ is the CO₂ price at time t .

⁶¹ Details of the price model for Subject 1 can be found in Chapter 5.

⁶² Details of the cash flow model for this case can be found in Chapter 4.

⁶³ A linear cash flow model makes the calculation of expected value of cash flow simpler, because the expected value of CO₂ price can be calculated separately and integrated into the calculation in one step.

$E(a+bP_{\text{CO}_2}) = a + b * E(P_{\text{CO}_2})$

⁶⁴ After-tax CO₂ emission costs can be defined as $P_{\text{CO}_2} * \text{Mass of CO}_2 * (1 - \text{marginal tax rate})$. Mass of CO₂ * (1 - marginal tax rate) is called the after-tax mass of CO₂ emissions.

In the deterministic decision approach, the year of retrofit (year T) is an upfront commitment in 2010 to retrofit in a given year in the future, no matter what CO₂ price is realized in that year. The assumption in this specific instance is that the median CO₂ price is realized in the year the upfront retrofit commitment is made (2010). Equation 6.4 is used in calculating the discounted cash flow for the deterministic retrofit case, using the DCF approach (Deterministic-DCF).

$$DCFCostNPV = \sum_{t=0}^T (a_{1,t} + b_{1,t} * E(P_{CO_2,t})) * \exp(-r * t) + \sum_{t=T+1}^{40} (a_{2,t} + b_{2,t} * E(P_{CO_2,t})) * \exp(-r * t) \quad (6.4)$$

where,

$E(P_{CO_2,t})$ represents the expected price of CO₂ in a future year t, conditioned on median price occurring in 2010, the year of the investment decision.

r = Project cost of capital, taken as 10% per year in our calculations.

Equation 6.5 is used in calculating the discounted cash flow for the deterministic retrofit case, using the MBV approach (Deterministic-MBV).

$$MBVCostNPV = \sum_{t=0}^T (a_{1,t} + b_{1,t} * FP_t(P_{CO_2,t})) * \exp(-r_f * t) + \sum_{t=T+1}^{40} (a_{2,t} + b_{2,t} * FP_t(P_{CO_2,t})) * \exp(-r_f * t) \quad (6.5)$$

where $FP(P_{CO_2,t})$ represents the forward price of CO₂ in a future year t, conditioned on median price occurring in 2010, the year the investment decision is being made.

r_f = risk-free rate, taken as 3% per year in our calculations.

The forward price in Equation 6.5 can be shown to be the same as the risk-adjusted expected price or certainty equivalent.⁶⁵ The manner in which the forward price is calculated from the expected price is shown in Equation 6.6 below.

$$FP(P_{CO_2,t}) = E_t(P_{CO_2,t}) * \exp(-P_{risk} * \sigma_{tot}) \quad (6.6)$$

where σ_{tot} is the cumulative volatility at time t, and includes the impact of the volatilities of all periods preceding t.

The DCF and MBV valuation are carried out assuming different retrofit years (T=1 to 39), and also assuming no retrofit. The cost NPVs in year 0 (2010, in our case) using DCF and MBV are shown in Figure 6.5 and 6.6 respectively. The expected prices and forward prices of CO₂ conditioned on the median price in 2010 are shown in Figure 6.7.

⁶⁵ David G. Laughton and Henry D. Jacoby (1992). "Project Duration, Output Price Reversion and Project Value". Institute for Financial Research, University of Alberta Working Paper No. 3-91.

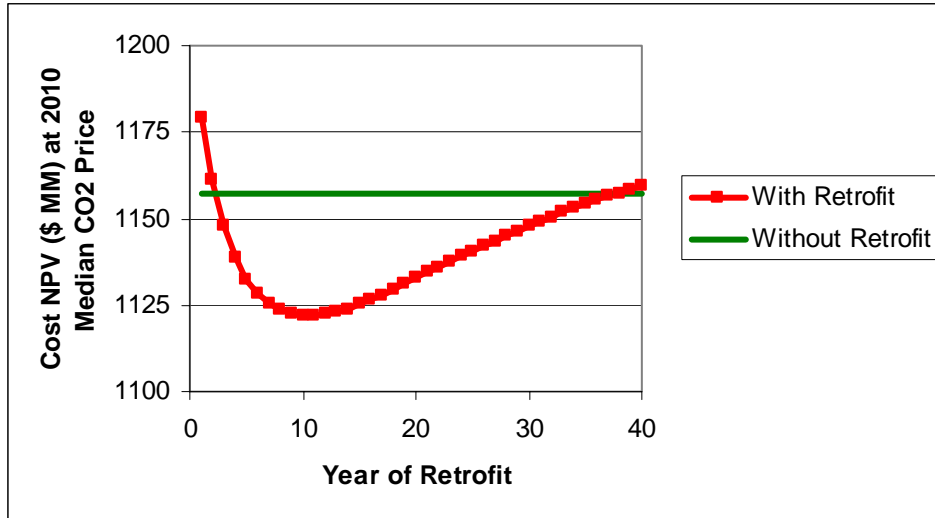

Figure 6.5: Cost NPV using DCF assuming deterministic retrofit is shown for the illustrative case. The minimum cost NPV occurs when the retrofit year = 11, and the minimum cost NPV = \$1122 million.

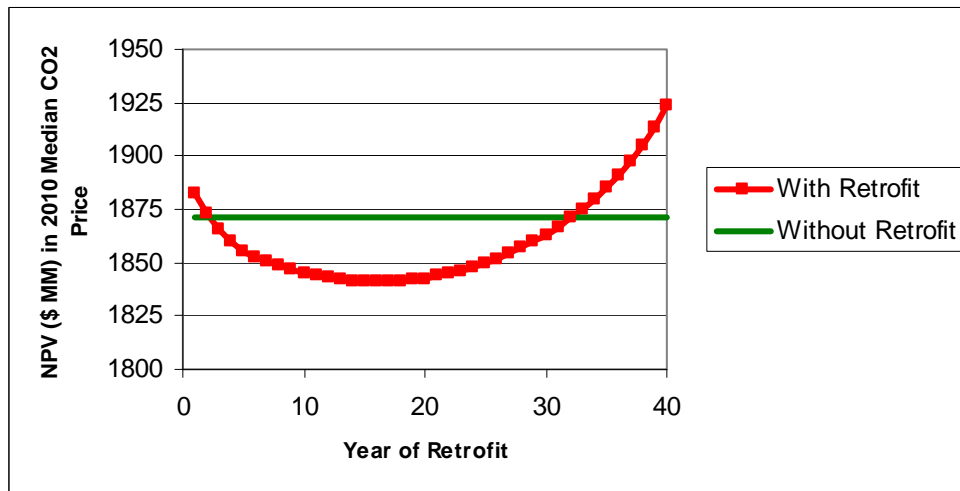

Figure 6.6: Cost NPV using MBV and assuming deterministic retrofit is shown for the illustrative case. The minimum cost NPV occurs when the retrofit year = 16, and the minimum cost NPV = \$1841 million.

The choice of retrofit year influences the timing and quantum of incremental benefits from reduced CO₂ emission costs, i.e., the earlier the retrofit, the greater are the

incremental benefits. At the same time, the retrofit year also influences the timing of additional retrofit and make-up plant (“retrofit”) investment costs, and timing and quantum of increased O&M and fuel costs. The tax shield increases or decreases based on the net incremental benefits of retrofit. The trade off between the discounted value of the reduction in CO₂ emission costs and the increase in investment and other operating costs results in the curves seen in Figure 6.5 and 6.6. It is seen that the optimal year of retrofit using MBV is year 16 (2036) with a cost NPV of \$1841 million, while the optimal year of retrofit using DCF is year 11 with a cost NPV of \$1122 million.

The DCF approach discounts all costs at 10% per year, including the CO₂ emission costs. On the other hand, the MBV risk-adjusts the CO₂ prices and calculates risk-adjusted costs. The risk-adjustment of CO₂ depends on the volatility, and can vary. All risk-adjusted costs are discounted at 3% per year. DCF therefore undervalues the after-tax non-CO₂ emission cost components ($a_{1,t}$ and $a_{2,t}$), while it may or may not undervalue CO₂ emission costs. The effective discounting of CO₂ emission costs (in % per year) in the DCF and MBV approaches is shown in Figure 6.8.

The analysis and the results presented show how DCF and the MBV valuation methods can be used while valuing deterministic retrofit decision making. They also show (Figures 6.5 and 6.6) that DCF substantially undervalues costs. Section 6.5 discusses this in more detail while answering research question (ii).

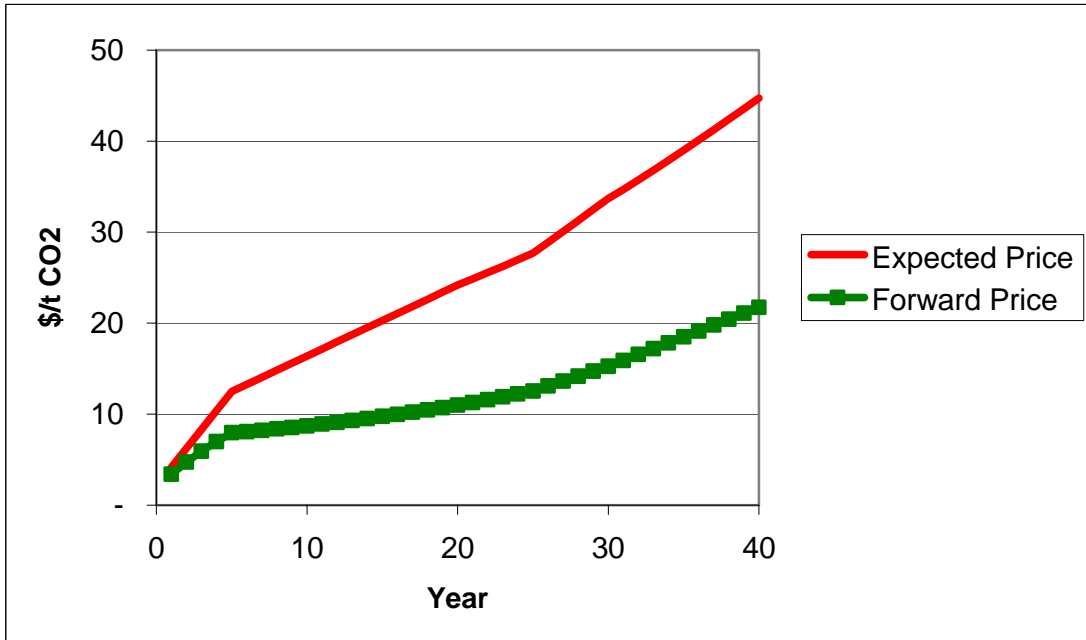

Figure 6.7: Expected and Forward CO₂ Prices conditioned on the median price in 2010. Year 0 corresponds to 2010. The difference between the expected and forward price shows the level of cumulative discounting.

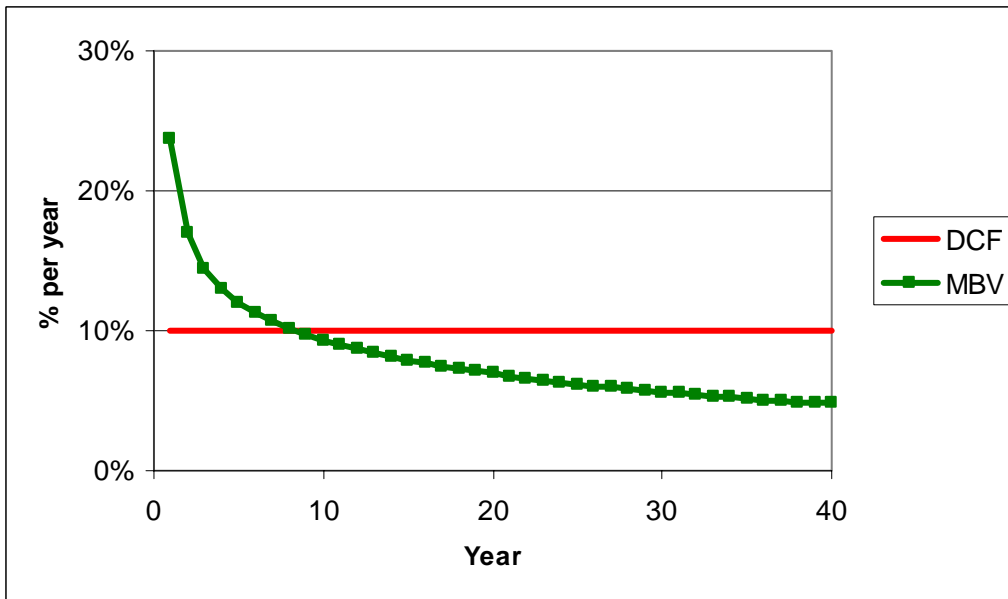

Figure 6.8: Effective discounting rates per year for CO₂ emissions costs using DCF and MBV. It can be seen that DCF underdiscounts CO₂ emission costs in the early years when prices are low, but then overdiscounts them when prices increase.

6.3.2 American DCF and MBV cases using Complete DCF Decision Trees and Real Options Analysis

A manager seeks dynamic control over asset management decisions to take into account new information about stochastic variables that influence asset performance. It is useful for the manager to capture the dynamic uncertainty of such stochastic variables in a scenario tree. The time steps on such a tree are determined by the desired temporal flexibility in exercising management options.

The CO₂ retrofit decision on a coal-fired power plant depends on the future stochastic CO₂ price path.⁶⁶ The decision to retrofit is evaluated on a continual basis,⁶⁷ taking into account investment costs, increased operating costs and reduced CO₂ emissions costs. It is, therefore, useful to represent future CO₂ prices as a scenario tree. The nodes in such a scenario tree are called “states”, and paths through these states represent scenarios.⁶⁸ The information contained in each state is unique, and the future price paths are influenced by this information upon realization of the state.

In the problem at hand, the time horizon was divided into 40 years, and cash flows and decision making occur every year. In each year, the continuum of possible CO₂ price points by a lattice of 200 discrete points starting \$0/t CO₂ and going to \$100/t CO₂ for Subjects 1 and 2, and by a lattice of 800 discrete points starting at \$0/t CO₂ and going to \$400/t CO₂ for Subject 3. The total number of nodes or states is 8000 or 32000.

⁶⁶ This is the case since this is the lone stochastic variable in the analysis. If there were two stochastic variables, then future decisions would depend on the scenarios of both stochastic variables.

⁶⁷ In the thesis, the manager of a coal-fired power plant has the option to retrofit at the end of every operating year.

⁶⁸ David Laughton (1998). “The Management of Flexibility in the Upstream Petroleum Industry”. The Energy Journal, Vol.19, No.1.

If retrofit has not been already done, the manager has two choices at each CO₂ price state: either to “retrofit” or “wait”⁶⁹. The decision options to “retrofit” and “wait” need to be evaluated for every CO₂ price state. The search for the best possible decision at any state is done using dynamic programming. In this method, the analysis of the best possible decision at any state is started at year 40, and then done backwards over time.

Let the NPV of future stochastic cash flows at the CO₂ price state being considered be V_{retrofit} if the decision at the price state is to retrofit, or be V_{wait} if the decision at that price state is to wait. The optimal value⁷⁰ in each price state is calculated using Equation 6.7.

$$V_{\text{optimal}} = \max (V_{\text{retrofit}}, V_{\text{wait}}) \quad (6.7)$$

At year 40, the calculation of V_{retrofit} and V_{wait} for different price states is straightforward given that there are no future cash flows to deal with at that time. V_{optimal} can be calculated using Equation 6.7 for each price state in year 40.

The next step is to implement the dynamic programming method is to find out V_{optimal} for each price state in year 39. V_{retrofit} at each state in year 39 can be determined using the methods discussed in Section 6.3.1. The term structure of CO₂ price expectations (DCF) or forward prices (MBV) is developed for each individual state, and is conditioned on the state being realized, using Equation 5.6 for the median price in the relevant state.

⁶⁹ Waiting implies not retrofitting at that state.

⁷⁰ The optimal decision is based on the optimal value.

The value of V_{wait} for each state is more difficult to calculate. At any state in year 39, it is, if DCF is used, the conditional expectation of V_{optimal} in year 40 discounted for time and risk using the cost of capital. If MBV is used, the risk-adjusted conditional expectation of V_{optimal} in year 40 is discounted for time using the risk-free rate.

Given the process for updating CO₂ price expectations, this is done for MBV by solving the Black-Scholes-Merton differential equation (Equation 6.8):⁷¹:

$$\frac{\partial V}{\partial t} + \frac{1}{2}\sigma^2 P^2 \frac{\partial^2 V}{\partial P^2} + (r - c)P \frac{\partial V}{\partial P} - rV = 0 \quad (6.8)$$

subject to the following boundary conditions:

$$V(\text{price} = 0, \text{year} = s) = V_{\text{optimal}}(\text{price} = 0, \text{time} = 40 \text{ years}) * \exp(-r(40 \text{ years} - s))$$

$$\text{And } P^2 \frac{\partial^2 V}{\partial P^2} \rightarrow 0, P \rightarrow \infty$$

V = Value of a claim to V_{optimal} in year 40.

σ = Short term volatility at that state.

P = contemporaneous price at that state

r = risk-free rate

c = a term commonly called “convenience yield”, which is derived from the price process. It is calculated at each time t using Equation 6.9.⁷²

⁷¹ David Laughton (1998). “The Potential for Use of Modern Asset Pricing Methods for Upstream Petroleum Project Evaluation: Introductory Remarks”. The Energy Journal Vol.19, 1.

All variables used in Equation 6.9 have been defined previously in Chapter 5 or earlier in this chapter.

$$c_t = r_f + P_{risk} * \sigma_t - \left(\frac{\partial M_0(P_t)}{M_0(P_t)} + \frac{1}{2} \sigma_t^2 - \gamma \ln \left(\frac{P_t}{M_0(P_t)} \right) \right) \quad (6.9)$$

To calculate V_{wait} using DCF, one can show that the same form of Equation 6.8 can be used, by using the weighted average cost of capital in place of r_f and setting $P_{risk}=0$ in Equation 6.9.

Once $V_{optimal}$ is determined for year 39, it can be used to determine V_{wait} for year 38 in the same way. This can be compared to $V_{retrofit}$ determined using Equation 6.5 with the terminal time set to 39 years instead of 40 years.

Using this recursive backwards approach of dynamic programming, the optimal value of the cash-flow resulting for an optimal retrofit policy can be determined for any price state at any prior time including 0.

The results of American option valuation using DCF and MBV for different CO_2 prices in 2010 are shown in Figure 6.9 for the illustrative case described in Table 6.2 earlier in this section. It should be noted that the probabilities of different CO_2 prices (and therefore cost NPVs) occurring in 2010 are determined by the log-normal distribution of prices in that year as viewed from now (2005).

⁷² David G. Laughton and Henry D. Jacoby (1992). "Project Duration, Output Price Reversion and Project Value". Institute for Financial Research, University of Alberta Working Paper No. 3-91.

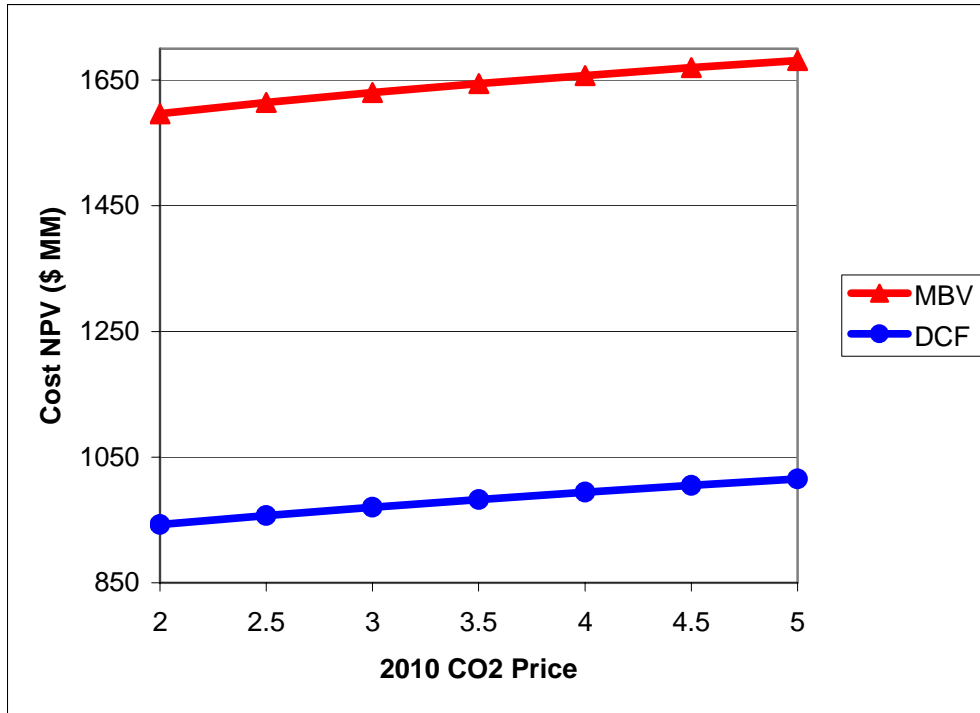

Figure 6.9: The cost NPV are plotted against different CO₂ prices in 2010 for both DCF and MBV assuming American option on retrofit. The median price in 2010 in the price scenario assumed is \$1.82/t CO₂. Note that Figures 6.5 and 6.6 describe the DCF and MBV values of deterministic retrofit assuming the median price of \$1.82/t CO₂ is realized in 2010.

It can be shown that V_{retrofit} is greater than V_{wait} above some level of threshold price in each year. A price simulation model using Equation 5.5 was used to determine the cumulative probability of retrofit in each year. The results of the cumulative retrofit probabilities assuming DCF and MBV are shown in Figure 6.10. It is seen that cumulative retrofit probability using MBV starts increasing starting year 5 with a near certain retrofit probability reached by year 15 (see Figure 6.10). It is seen that optimal year of deterministic retrofit is year 16 if MBV is used, which is just about when there is near certainty of retrofit (year 18) assuming flexible retrofit. On the other hand it is seen that optimal year of deterministic retrofit is year 11 if DCF is used, which is earlier than

when there is near certainty of retrofit (year 22) assuming flexible retrofit. The value gained in flexibility in the case of MBV is from opportunities to retrofit earlier at states that have higher than critical prices, while the value of flexibility is from not retrofitting early at price states that are lower the critical prices.

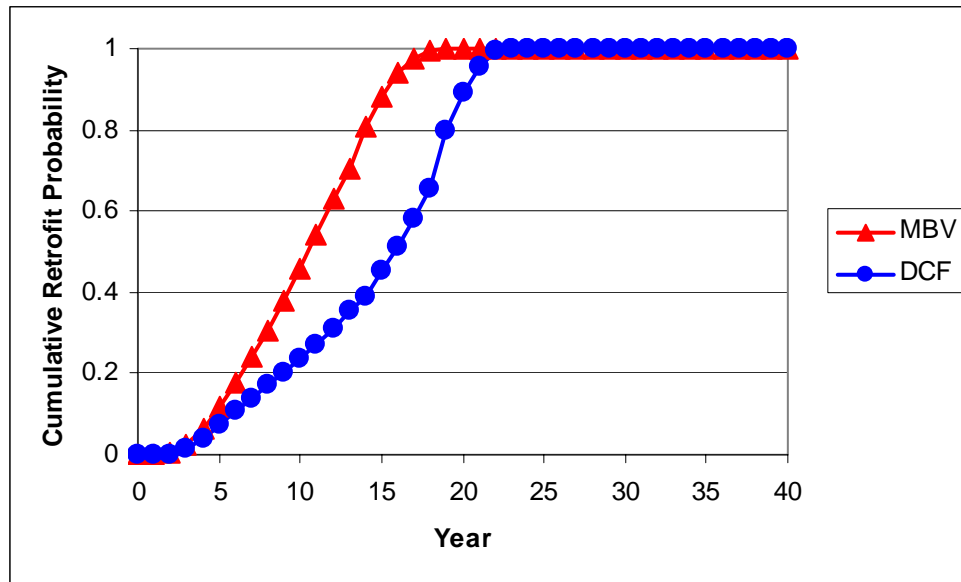

Figure 6.10: The cumulative retrofit probability over time for MBV and DCF for the illustrative case is shown. Note in the deterministic cases in Section 6.3.1, the cumulative probability of retrofit is 0 before deterministic year of retrofit and 1 after the deterministic year of retrofit.

6.4 Research Question (i): What is the economic value of temporal flexibility of making the retrofit decision?

The fundamental value of an option to retrofit as compared to deterministic retrofit has been discussed in Sections 6.3.1 and 6.3.2. A manager with an option to retrofit optimizes decision making on a state-by-state basis. On the other hand, pre-committing to a decision to retrofit in any year, including the optimal year of deterministic retrofit (Figures 6.5 and 6.6), is inferior to an option to retrofit.

As was discussed in Section 6.3.2, analysis of the American retrofit option reveals a critical CO₂ price in every year above which it makes economic sense to retrofit as opposed to wait. The manager with the American option to retrofit can choose to retrofit only at CO₂ price states greater than the critical CO₂ price in that year. The decision making by such a manager takes full advantage of the flexibility in decision making, and optimizes between waiting and retrofitting at each CO₂ price state.

On the other hand, a manager who has committed to a deterministic retrofit ends up retrofitting at CO₂ price states that are lower than the critical price in that year. Further, the manager does not capitalize on opportunities to retrofit at CO₂ price states at times earlier than the retrofit year, and avoid retrofit at CO₂ price state at times after the retrofit year. The value lost on account of this sub-optimality in deterministic decision making is the value of retrofit flexibility.

The value of retrofit flexibility is defined as the percentage reduction in cost NPV as one goes from deterministic retrofit to American option on retrofit. The retrofit flexibility values for the cases described in Table 6.3 below are shown in Figure 6.11.

Table 6.3: Value of retrofit flexibility: Case description

CO ₂ Price Model	Subjects 1, 2 and 3
Cash Flow Model	Pre-investment IGCC
Retrofit flexibility	American Option
Valuation methodology	MBV
Fuel Price	\$1.1/million Btu

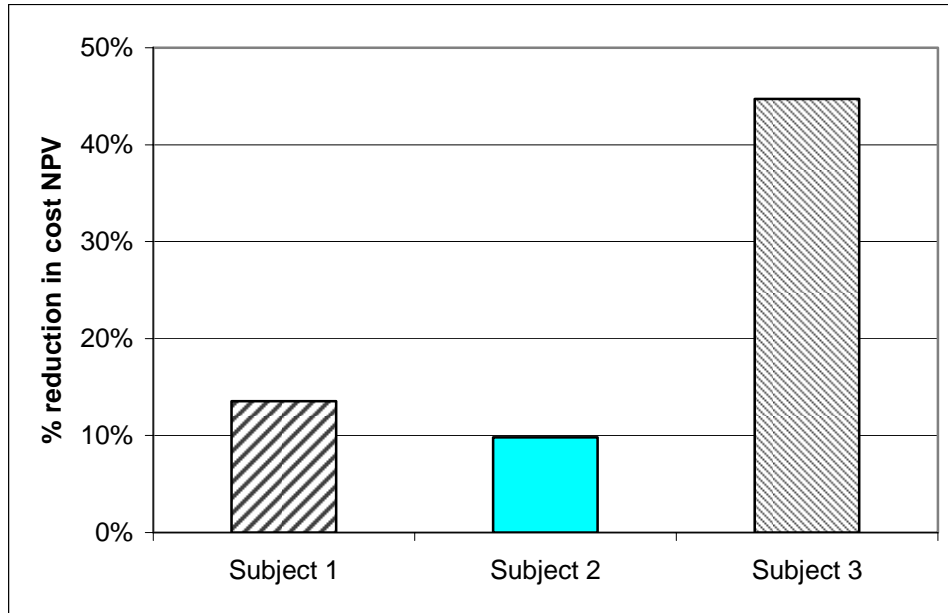

Figure 6.11: Value of retrofit flexibility determined as the reduction in cost NPV using MBV, as one moves from deterministic retrofit to an American option to retrofit. This exercise was done for pre-investment IGCC, at a fuel price of \$1.1/million Btu, assuming dynamic quantitative CO₂ price models of Subject 1, Subject 2 and Subject 3. Chapter 5 provides details on these price models.

It can be seen from Figure 6.11 that the value of retrofit flexibility varies widely based on CO₂ price models used. The discussion that follows attempts to explain the reasons for different retrofit flexibility values for different price models.

It can be seen from Figure 6.11 that the value of retrofit flexibility is highest in Subject 3's price model. This is primarily driven by high risk-adjusted CO₂ prices, despite high price uncertainties (see Figures 5.1, 5.2, 5.3 and 5.4). In Subject 3's price model, the flexibility of retrofit results in a substantial cumulative probability of retrofit in the early years (Figure 6.12) that captures the benefit of high CO₂ price states without absorbing the negative value of retrofitting at low CO₂ price states. Further, with retrofit flexibility, it is nearly certain that the asset will be retrofit by year 16, while the optimal

year for deterministic retrofit is year 23. The benefits of avoided CO₂ emission costs during this period add to the value of retrofit flexibility.

The value added through retrofit flexibility is much lower in Subject 1's model than it is in Subject 3's model. One reason for this is the substantially higher risk-adjusted prices in the later years in Subject 3's price model as compared to Subject 1's, despite marginally lower risk-adjusted prices in earlier years. Because of this, the optimal year for deterministic retrofit is earlier in Subject 1's case (year 16) as compared to Subject 3's (year 23). The benefits of flexible retrofit are lower for Subject 1 than they are for Subject 3 because of an earlier optimal deterministic retrofit year.

In Subject 2's price model, the risk-adjusted CO₂ prices are lower than they are in Subject 1's and Subject 3's, and the CO₂ price uncertainties are substantial. The risk-adjusted prices are low enough that deterministic retrofit is always worse than operating the asset without retrofit. Retrofit flexibility does not provide much value till year 28 (2038), as can be seen from the negligible cumulative probability of retrofit. However, between years 28 and 30, retrofit become nearly certain. The value added through retrofit in these years when compared to not retrofitting, represents the value of retrofit flexibility. The value of retrofit flexibility in Subject 2's case will be substantial in the later years (years 28 through 40), but end up being lower than Subject 1's because of time discounting effect.

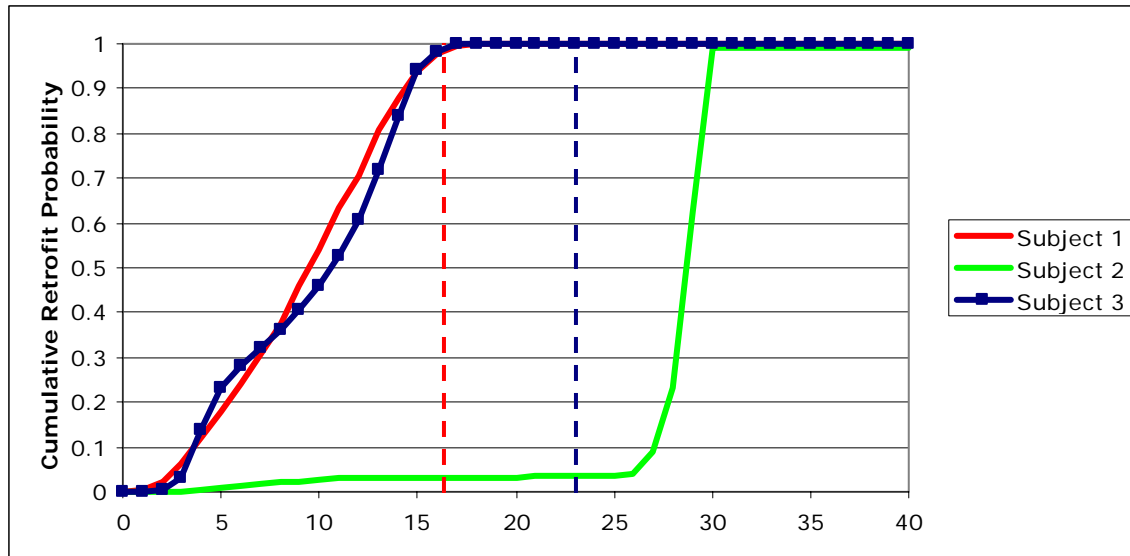

Figure 6.12: Cumulative retrofit probability for Pre-investment IGCC using MBV and assuming flexibility in retrofit decision making, assuming the CO₂ price models of Subjects 1, 2 and 3. The “dashed” lines show the year of optimal deterministic retrofit – for Subject 1, it is year 16 while for Subject 3, it is year 23. For Subject 2, it is optimal to pay the CO₂ emissions cost without committing to retrofitting – which is the reason for not finding a green dashed line. Fuel price assumed is \$1.1/million Btu.

As can be seen from the preceding discussion, the values of retrofit flexibility increase as magnitudes of CO₂ prices and uncertainties increase. It is also seen that retrofit flexibility increases as the spread between the cumulative retrofit probability curve and the year of optimal deterministic year widens. The quantitative method and the tool to analyze such impacts has been developed, and can be used to help gain an insight into the value drivers of flexibility in retrofit decision making.

6.5 Research question (ii): How does the choice of valuation methodology (DCF v. MBV) impact the investment decision to become “capture-ready”?

Pre-investment IGCC is considered to be “capture ready” in comparison to PC and baseline IGCC technologies in addressing this question. Research question (ii) effectively reduces to understanding the impact of the choice of valuation method on the competitiveness of pre-investment IGCC vis-à-vis PC and baseline IGCC. This is illustrated by using evaluating all three technologies using the case described in Table 6.4. The results of the analysis are summarized in Table 6.5.

Table 6.4: Case description for analyzing impact of valuation method on “capture-ready” technology

CO ₂ Price Model	Subject 3
Cash Flow Model	Pre-investment IGCC, baseline IGCC and PC
Retrofit flexibility	American Option
Valuation methodology	MBV and DCF
Fuel Price	\$1.1/million Btu

Table 6.5: Comparison of Cost NPV of the three technologies using MBV and DCF for illustrative case in Table 6.4 conditioned on median CO₂ price in 2010

	MBV (\$ million)	DCF (\$ million)
Pre-investment IGCC	1008	969
Baseline IGCC	978	948
PC	971	959
Cost Difference (pre-investment IGCC and PC)	37 (3.8%)	10 (1.0%)
Cost Difference (pre-investment IGCC and baseline IGCC)	30 (3.1%)	21 (2.2%)

It can be observed in Table 6.5 that the cost NPV disadvantages of pre-investment IGCC compared to PC and baseline IGCC reduce as we move from MBV from DCF. DCF, therefore, makes the “capture-ready” technology look better than it does under MBV analysis.

Analysis conducted using CO₂ price models of Subjects 1 and 2 reveal similar trends. However, the extent to which DCF makes pre-investment IGCC look better, depends on the CO₂ price model. It is found that DCF makes pre-investment IGCC more competitive as CO₂ price uncertainty increases. Similar analysis shows that DCF makes pre-investment IGCC more competitive compared to PC, and less competitive compared to baseline IGCC, as fuel price increases.

7. Analysis of Results

This chapter is devoted to answering research question (iii) in Chapter 1, which is the key research question in this thesis: *“Among the coal-fired power plant technologies, which should a firm choose to invest in, given an uncertain carbon policy? What are the economic factors that influence this choice?”*

Section 7.1 presents the results of the economic valuation of the technologies assuming flexible retrofit decision making using the MBV approach. Cash flow models for the different technologies are drawn from Chapter 4, and CO₂ price models are taken from Chapter 5. Section 7.2 provides detailed analysis of the results shown in Section 7.1. Section 7.3 presents and analyzes the sensitivity of the results obtained in Section 7.1 to change in fuel prices.

It should be noted that the results obtained strongly depend on the cash flow and CO₂ price models. Change in the assumptions underlying these models will change the results.

7.1 Economic Comparison of the Three Technologies

Using the MBV approach for valuing American options⁷³, the three technology options are compared in two pairs for the Subject 1 CO₂ price model, at a constant fuel price of \$1.1/million Btu. The description of the case is provided in Table 7.1.

Comparison of the first pair of baseline IGCC and pre-investment IGCC is done in Section 7.1.1. Section 7.1.2 compares the more cost-effective technology in Section 7.1.1 with PC. Section 7.1.3 investigates the impact of the effect of Subject 2's and

⁷³ This is the preferred valuation method, and reasons for this are discussed in Section 6.2.

Subject 3's CO₂ prices models on the results obtained in Section 7.1.1 and 7.1.2 and provides as analysis of the results.

Table 7.1: Case description for comparing the technologies.

CO ₂ Price Model	Subject 1
Cash Flow Model	Pre-investment IGCC, Baseline IGCC and PC.
Retrofit flexibility	American Option
Valuation methodology	MBV
Fuel Price	\$1.1/million Btu

7.1.1 Comparison of Baseline IGCC and Pre-Investment IGCC

The cost NPVs of baseline IGCC and pre-investment IGCC for different CO₂ prices in 2010 is presented in Figure 7.1. Figure 7.2 shows the difference in cost NPV between pre-investment IGCC and baseline IGCC. A positive number for the difference means that baseline IGCC has a lower cost NPV and is therefore preferred. It is evident from Figure 7.2 that baseline IGCC is preferred over pre-investment IGCC over a wide range of CO₂ prices in 2010. This implies a near 100% chance that baseline IGCC will be preferred over pre-investment IGCC in this scenario. This probability is calculated based on the median, 10th and 90th fractiles of log-normal distribution of CO₂ prices in 2010, shown in Table 5.3 for Subjects 1, 2 and 3.

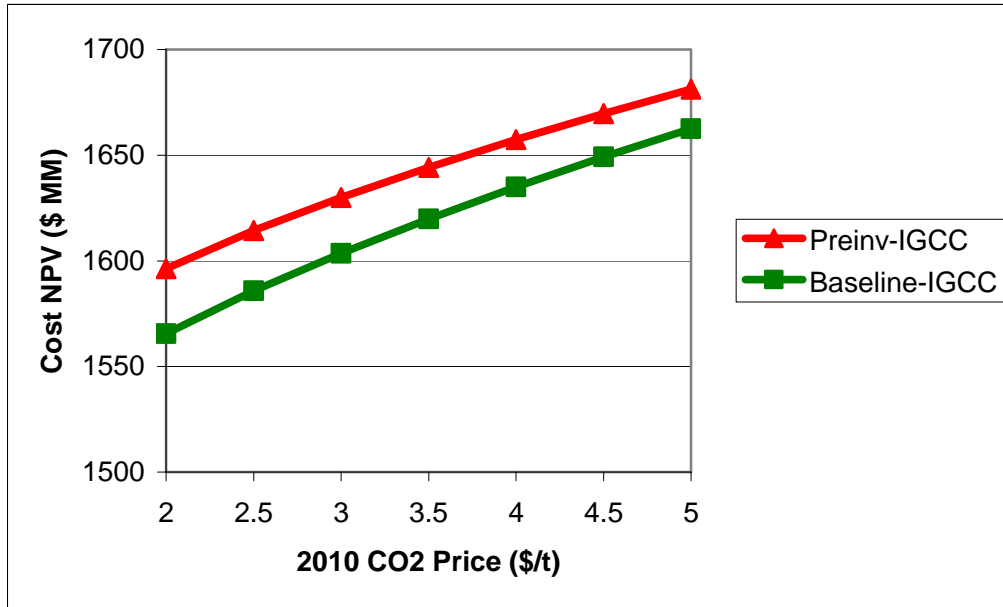

Figure 7.1: Cost NPV of pre-investment IGCC and baseline IGCC for difference prices of CO₂ in 2010. The median CO₂ price in 2010 is \$1.82/t.

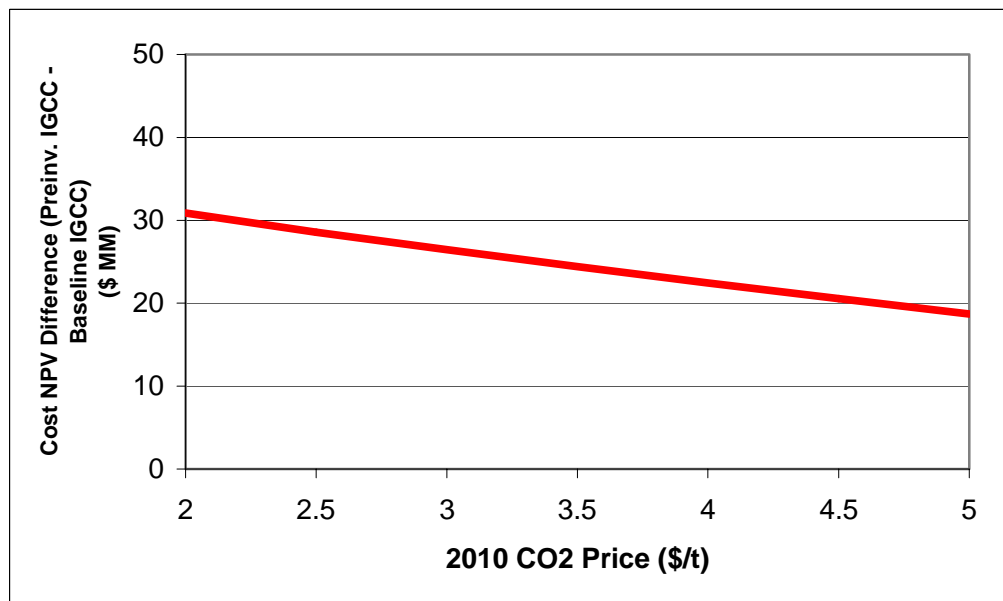

Figure 7.2: Cost NPV difference between Pre-investment IGCC and Baseline IGCC. A positive value indicates that baseline IGCC has a lower cost NPV, and is therefore preferable. The median CO₂ price in 2010 is \$1.82/t.

7.1.2 Comparison of Baseline IGCC and PC

Section 7.1.1 revealed that baseline IGCC is more cost effective than pre-investment IGCC over a wide range of CO₂ prices in 2010, and was therefore picked for the comparison with PC in the second step. The cost NPVs of baseline IGCC and PC for different CO₂ prices in 2010 is shown in Figure 7.3. Figure 7.4 shows the difference in cost NPV between baseline IGCC and PC at different 2010 CO₂ prices. A positive number for the difference means that PC has a lower cost NPV and is therefore preferred. Figure 7.4 shows that PC is preferred over baseline IGCC till a price of \$3.5/t CO₂ is reached in 2010. This corresponds to an approximately 91% chance that PC will be preferred over baseline IGCC.

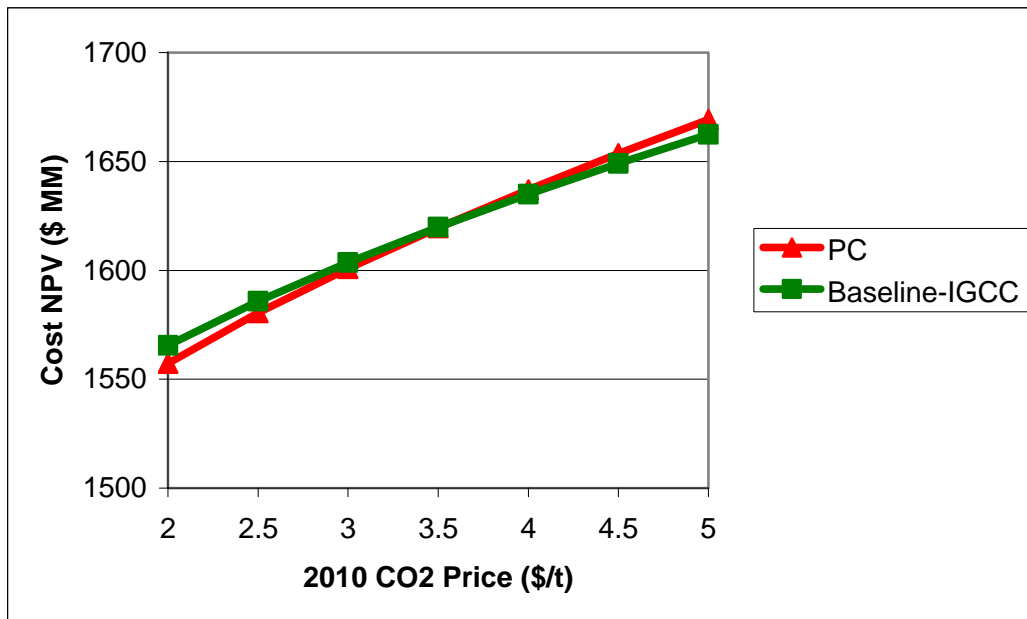

Figure 7.3: Cost NPV of baseline IGCC and PC for difference prices of CO₂ in 2010. The median CO₂ price in 2010 is \$1.82/t.

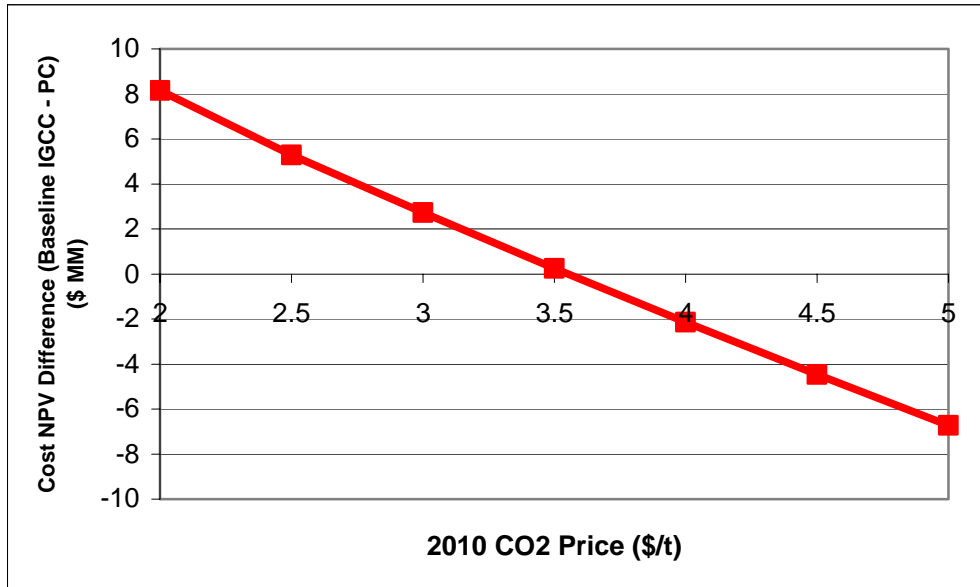

Figure 7.4: Cost NPV difference between baseline IGCC and PC. A positive value indicates that PC has a lower cost NPV, and is therefore preferable. The median CO₂ price in 2010 is \$1.82/t, and the 90th fractile is \$3.41/t. PC is preferred over baseline IGCC till a price of \$3.5/t CO₂ in 2010.

7.1.3 Comparison of Three Technologies using Subject 2 and Subject 3

CO₂ Prices

Comparison of Pre-investment IGCC and Baseline IGCC for Subject 2 and Subject 3

Price Models

A comparison of pre-investment IGCC and baseline IGCC for the case described in Table 7.1 were carried out, substituting Subject 2 and Subject 3 for Subject 1. The results of the cost NPV difference between pre-investment IGCC and baseline IGCC for all three CO₂ price models is shown in Figure 7.5. It is seen that there is a 100% chance that baseline IGCC is preferred over pre-investment IGCC in all three price models.

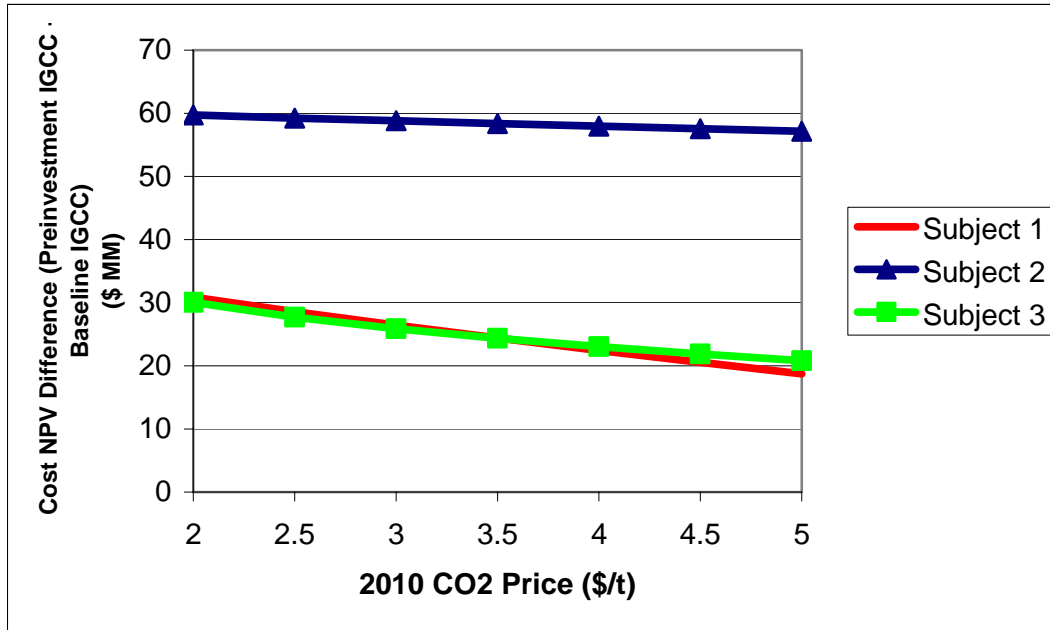

Figure 7.5: Cost NPV difference between pre-investment IGCC and baseline IGCC. A positive value indicates that baseline IGCC has a lower cost NPV, and is therefore preferable. It can be seen that baseline IGCC is preferable to pre-investment IGCC for all three CO₂ price models.

Comparison of Baseline IGCC and PC for Subject 2 and Subject 3 Price Models

A comparison of baseline IGCC and PC for the case described in Table 7.1, substituting Subject 2 and Subject 3 for Subject 1. The results of the cost NPV difference between baseline IGCC and PC for all the three CO₂ price models is shown in Figure 7.6. It can be seen that PC is preferred over baseline IGCC for a wide CO₂ price range in 2010 for Subject 2, up to \$3.4/t CO₂ for Subject 3, and up to \$3.5/t CO₂ for Subject 1. This implies that the chances of PC being preferred over baseline IGCC are approximately 91%, 100% and 88% in the Subject 1, Subject 2 and Subject 3 CO₂ price models respectively.

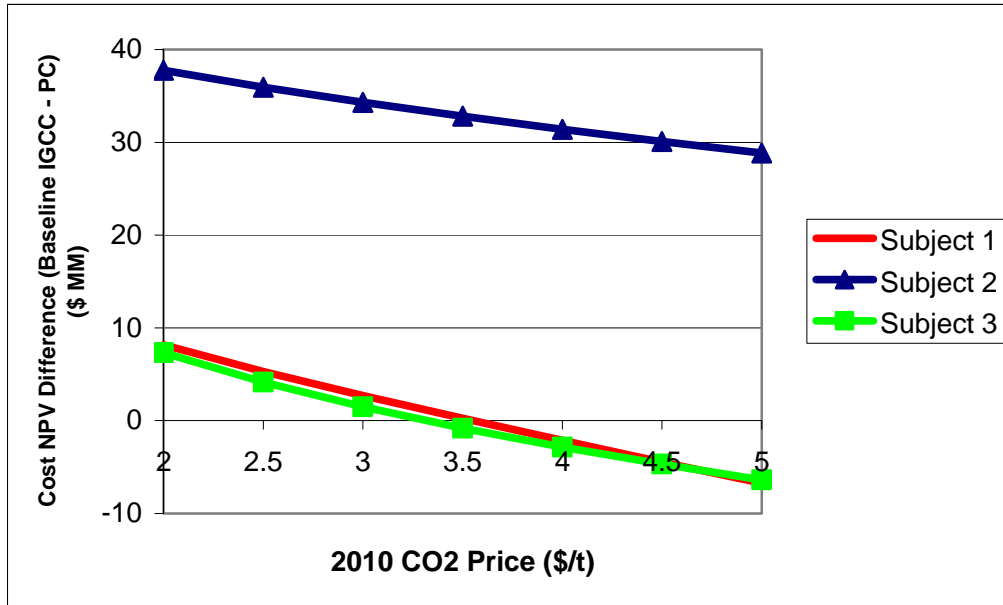

Figure 7.6: Cost NPV difference between baseline IGCC and PC. A positive value indicates that PC has a lower cost NPV, and is therefore preferable. It can be seen that baseline IGCC is preferable to pre-investment IGCC for all three CO₂ price models.

7.2 Analysis of Results of Economic Comparison

Pre-investment IGCC versus Baseline IGCC

Based on the cash flow models in Chapter 4, baseline IGCC is more cost-effective than pre-investment IGCC in all three CO₂ price models. The retrofit probability curves of pre-investment and baseline IGCC have the same pattern in the Subject 1 and Subject 3 price models (Figures 7.7 and 7.9 respectively). Baseline IGCC is more cost effective than pre-investment IGCC by approximately the same amount for both Subject 1 and Subject 3 price models (Figure 7.6).

This can be explained by the comparable impact of the risk adjusted prices of Subject 1 and Subject 3 on retrofit decision making.⁷⁴ The resultant savings in

⁷⁴ The expected prices of Subject 3 are substantially higher than those of Subject 1.

discounted CO₂ emissions of pre-investment IGCC over those of baseline IGCC are not high enough to overcome the disadvantages of the higher upfront investment costs in the case of pre-investment IGCC. A higher risk-adjusted CO₂ price path could have resulted in higher savings in discounted CO₂ emissions of pre-investment IGCC over those of baseline IGCC, and be adequate enough to overcome the disadvantage of higher upfront costs.

In Subject 2's price model, the relatively low risk-adjusted CO₂ prices (compared to Subject 1's and Subject 3's) are adequate to drive late retrofit (after year 26) of pre-investment IGCC but inadequate for baseline IGCC to retrofit at all. Figure 7.8 also shows that the retrofit probability of pre-investment IGCC remains relatively low till year 26, and increases rapidly to unity by year 30. In such a situation, the benefits gained by pre-investment IGCC over baseline IGCC in terms of lower discounted CO₂ costs are not high enough to offset the disadvantages of higher upfront investment costs.

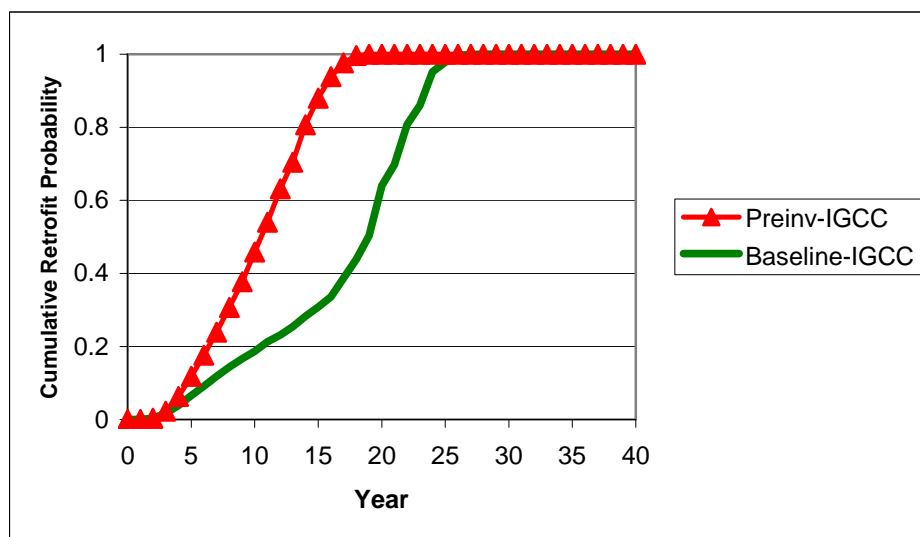

Figure 7.7: Subject 1: Cumulative retrofit probabilities of pre-investment and baseline IGCC.

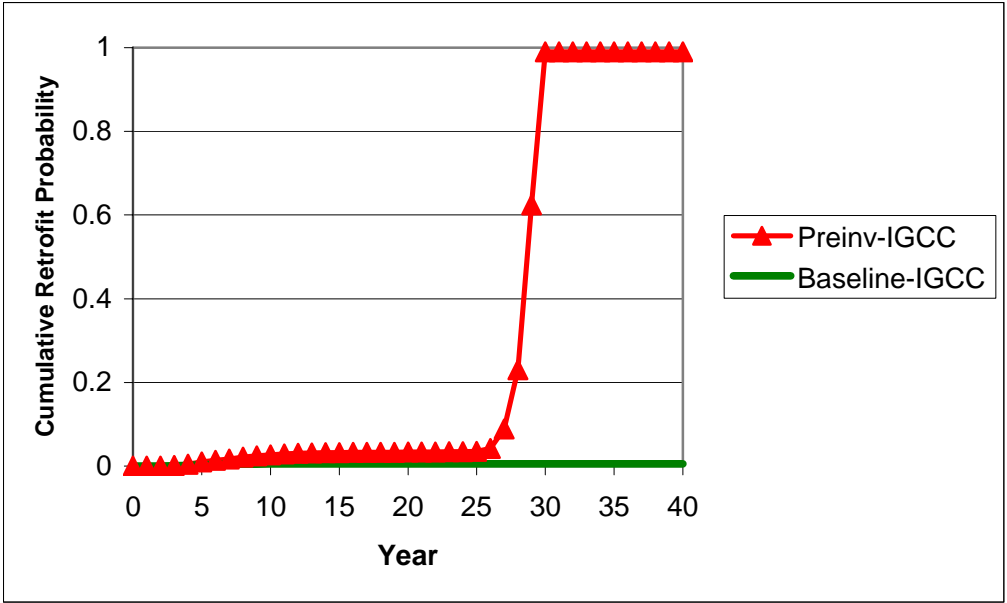

Figure 7.8: Subject 2: Cumulative retrofit probabilities of pre-investment and baseline IGCC.

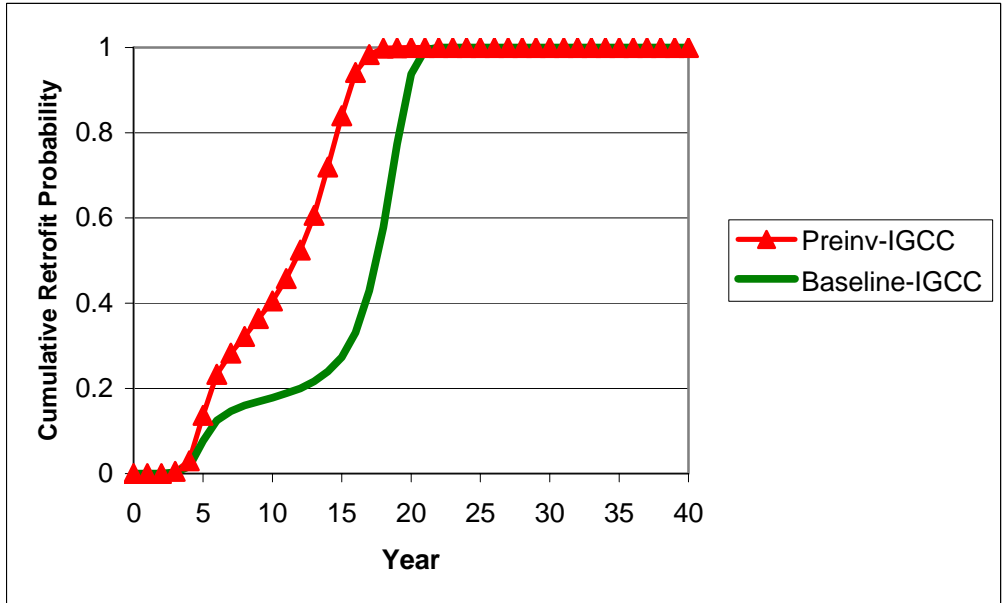

Figure 7.9: Subject 3: Cumulative retrofit probabilities of pre-investment and baseline IGCC.

Baseline IGCC versus PC

Subject 1's price model results in a high probability of baseline IGCC and a low probability of PC retrofitting (Figure 7.10). Substantial CO₂ prices are required for PC to retrofit and the probability of such prices occurring in Subject 1's price model are small. In this model, baseline IGCC after retrofit has advantages over PC in terms of CO₂ emissions costs. However, there is a low probability that the advantages of higher discounted CO₂ emissions costs of baseline IGCC will offset its disadvantages of higher upfront investment costs and operating costs. This results in a 91% chance of PC being more cost effective than baseline IGCC.⁷⁵

In Subject 3's price model, baseline IGCC starts to retrofit around the same time that it does in Subject 1's price model. However, the manner in which PC retrofits is different. PC starts to retrofit when there is a sudden price spike occurs in year 25. By then there it is nearly certain that baseline IGCC is already retrofitted. In this situation, the probability is low that the advantages of lower discounted CO₂ emissions costs of baseline IGCC will overcome its higher upfront investment and operating cost disadvantage. PC stands an 88% chance of being more cost-effective than baseline IGCC using Subject 3's price model.

In Subject 2's low risk-adjusted price model, neither PC nor baseline IGCC is retrofitted over their useful lives (Figure 7.11). The upfront investment cost advantage of PC is higher than the disadvantages of greater discounted operating and CO₂ emissions costs. PC has a 100% chance of being more cost-effective than baseline IGCC using Subject 2's price model.

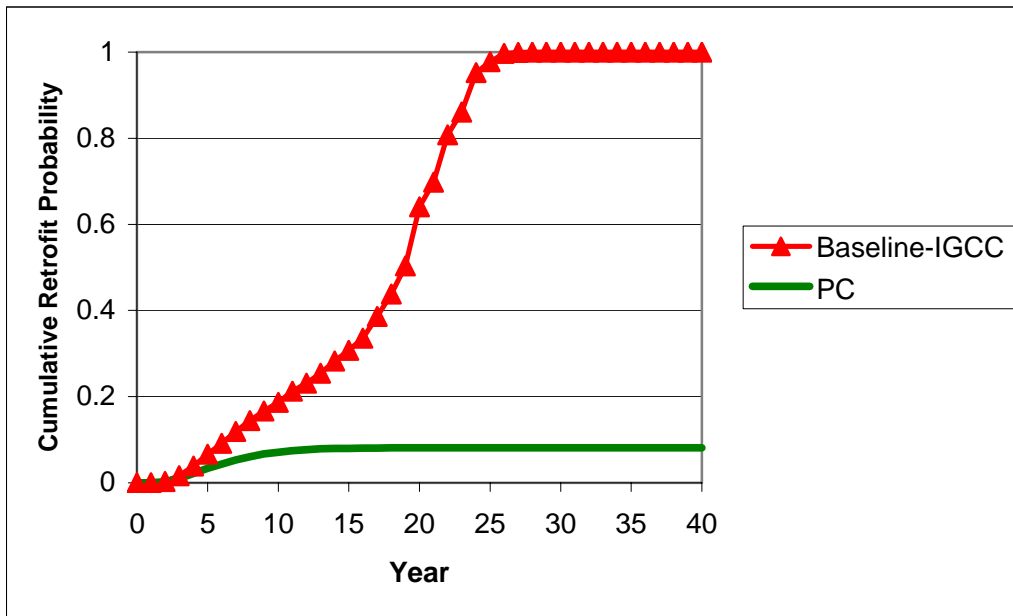

Figure 7.10: Subject 1: Cumulative retrofit probabilities of PC and Baseline IGCC.

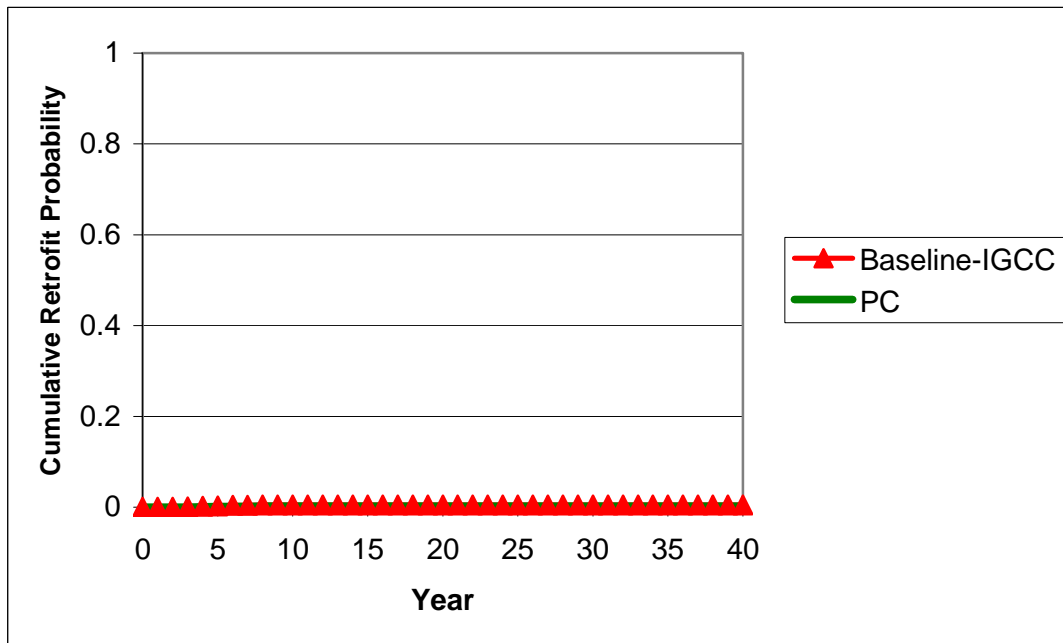

Figure 7.11: Subject 2: Cumulative retrofit probabilities of PC and baseline IGCC.

⁷⁵ As seen in Section 7.1.3.

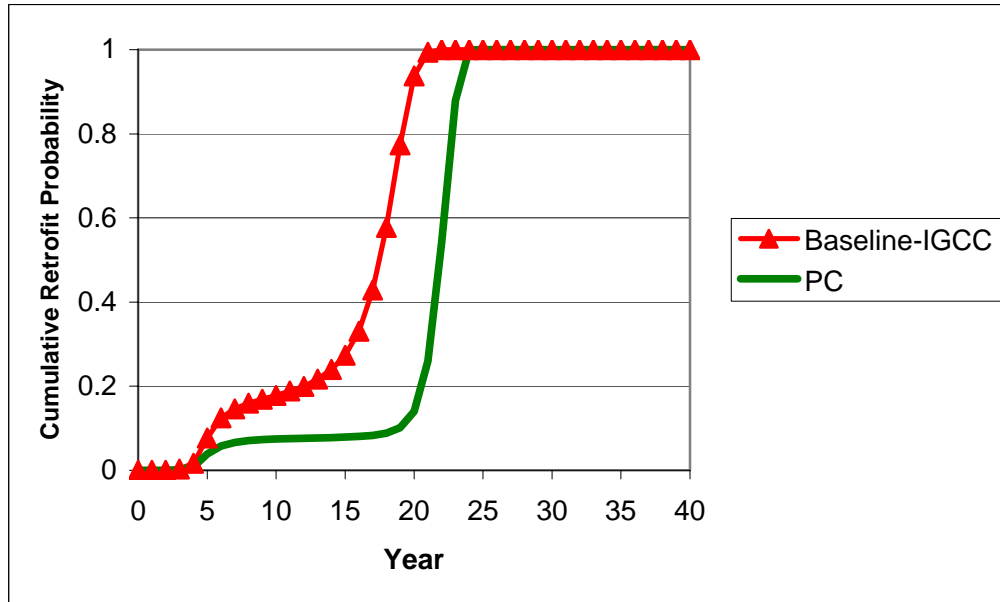

Figure 7.12: Subject 3: Cumulative retrofit probabilities of PC and baseline IGCC.

7.3 Sensitivity Analysis: Impact of Fuel Prices on Technology Choice

The objective of the sensitivity analysis is to understand the implications of stochastic fuel price on technology choice. As discussed in Chapter 3, the limitations of having to choose one stochastic variable necessitated the omission of fuel price as the second stochastic factor.

This section provides the results and analyses the sensitivity of fuel prices on the results obtained in Section 7.1.2.⁷⁶ The description of the case for sensitivity analysis is shown in recapped in Table 7.2. The results obtained when Subject 2's and Subject 3's price models are used are qualitatively similar.

Table 7.2: Case description for sensitivity analysis

CO ₂ Price Model	Subject 1
Cash Flow Model	Baseline IGCC and PC.
Retrofit flexibility	American Option
Valuation methodology	MBV
Fuel Price	\$1.5/million Btu and \$2/million Btu

The results of the cost NPV difference between baseline IGCC and PC is shown for the sensitivity cases in Table 7.2, along with the base case, is shown in Figure 7.13.

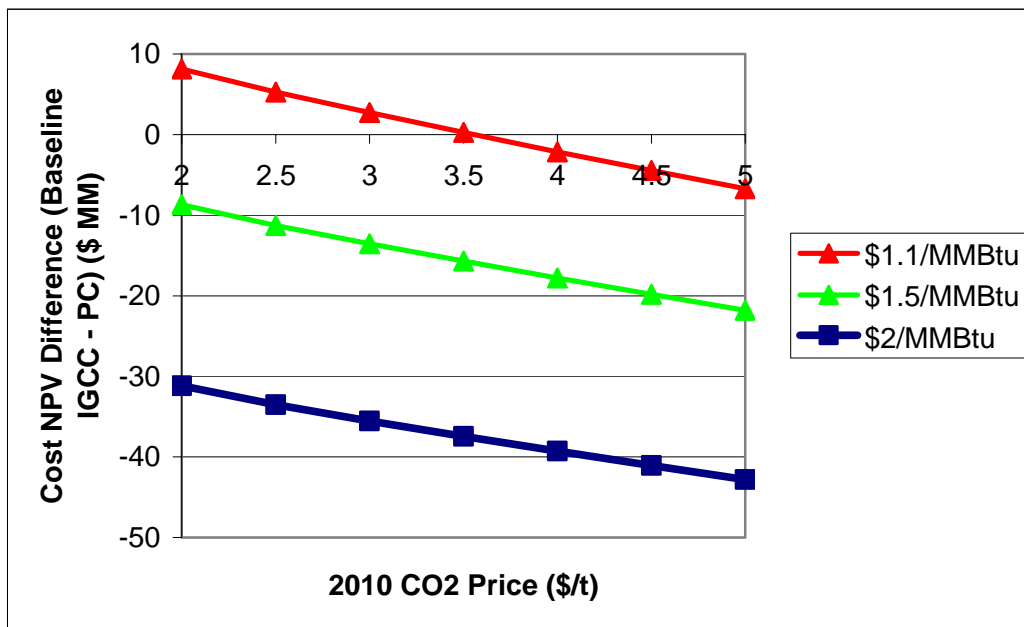

Figure 7.13: Cost NPV difference between baseline IGCC and PC for three fuel prices. A positive number implies that PC has a cost advantage. Median CO₂ price in 2010 is \$1.82/t.

⁷⁶ This is done using a fuel price of \$1.1/million Btu.

Analysis and conclusions

It can be seen from Figure 7.13 that baseline IGCC becomes increasingly cost effective as fuel price increases. The advantages of discounted CO₂ emissions costs of baseline IGCC over PC decrease as fuel prices increase. This is because the retrofit probability of baseline IGCC decreases with increase in fuel prices while the retrofit probability of PC remains virtually unchanged at close to zero (Figure 7.14 and 7.15).⁷⁷ However, the operating cost advantages of baseline IGCC over PC, driven by lower fuel costs, increase substantially with increase in fuel prices. The net impact is that the baseline IGCC becomes more cost effective than PC as fuel prices increase. At a fuel price of \$1.1/million Btu, there is a 91% chance that PC will be more cost-effective than baseline IGCC. At fuel prices of \$1.5/million Btu and \$2/million Btu, there is a 100% chance that baseline IGCC will be more cost-effectiveness than PC.

It can be seen from the above illustrative analysis that the economic comparison of technologies is sensitive to fuel price changes. In future work, cash flow models should incorporate fuel price as a stochastic variable along with CO₂ price.

⁷⁷ Base case (\$1.1/million Btu) is shown in figure 7.10.

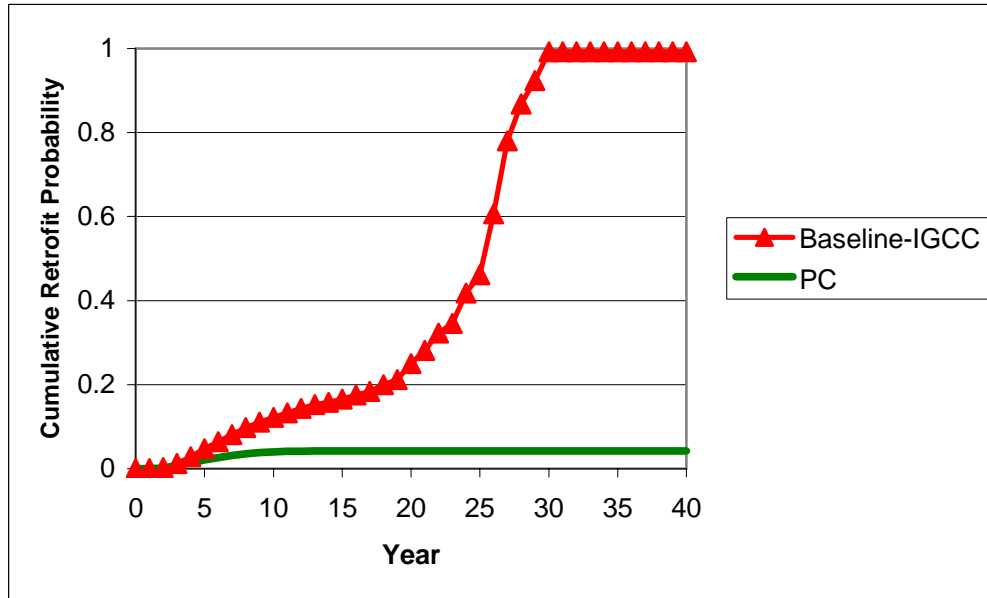

Figure 7.14: Cumulative retrofit probabilities for PC and baseline IGCC for a fuel price of \$1.5/million Btu.

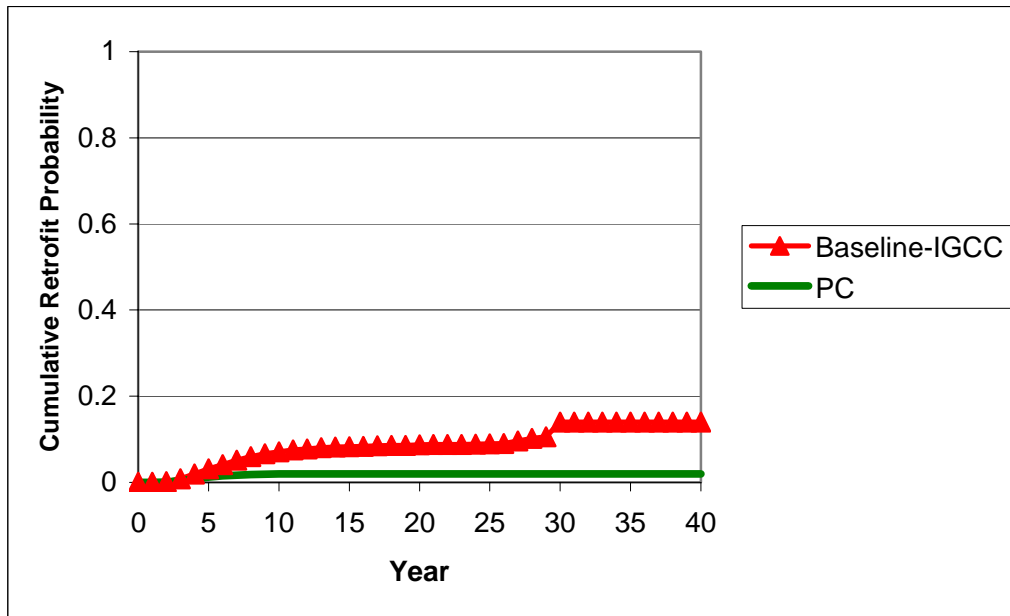

Figure 7.15: Cumulative retrofit probabilities for PC and baseline IGCC for a fuel price of \$2/million Btu.

8. Conclusions and Scope for Future Work

8.1 Conclusions

The objective of the thesis is to address the three research questions raised in Chapter 1 using the investment valuation tool that was developed. The conclusions presented in response to these questions are based on the cash flow models for specific representative cases of the technologies that use CO₂ price models of Subjects 1, 2 and 3. While efforts have been made to keep the inputs to the tool as representative as possible, it is up to the investor to develop their own independent estimates of these inputs. The conclusions reached on the three research questions are summarized below.

Question 1: What is the economic value of temporal flexibility in making the retrofit decision?

There is substantial economic value of temporal flexibility in retrofit decision making, and it increases with increase in CO₂ price uncertainty. This represents the value added by being able to make a retrofit decision based on the CO₂ price at that time as opposed to pre-committing on a future retrofit decision. The value of retrofit flexibility ranged from 10% - 44% in the illustrative case using different CO₂ price models. These values will change with if the assumptions on the cash flow and CO₂ price models are changed.

Question 2: How does the choice of valuation methodology (DCF v. MBV) impact the investment decision to become “capture-ready”?

Based on our input assumptions, it is seen that pre-investment IGCC, which is a “capture-ready” technology in comparison to baseline IGCC and PC, remains the least cost-competitive using both valuation approaches. However, the cost disadvantage of pre-investment IGCC increases if we use the MBV method in place of the standard DCF method currently in use. This is primarily driven by the fact that DCF undervalues costs compared to MBV in this case. However, it is plausible that the results may be different if new assumptions are made on cash flow models, CO₂ price models and other economic parameters (such as WACC, risk-free rate, CO₂ price of risk).

In the illustrative case, the cost disadvantage of pre-investment IGCC compared to PC reduced from 3.8% using MBV to 1% using DCF. At the same time, its cost disadvantage compared to baseline IGCC reduced from 3.1% using MBV to 2.2% using DCF.

Question 3: Among the coal-fired power plant technologies, which should a firm choose to invest in, given an uncertain carbon policy? What are the economic factors that influence this choice?

For our set of input assumptions, it is seen that PC has an 88% - 100% chance of being the optimal technology choice. The low upfront investment and operating costs of PC before retrofit outweighs the disadvantages of higher discounted CO₂ emission costs in all three price models. Pre-investment IGCC ends up as the least cost-effective option, while baseline IGCC falls in-between. PC would have been even further ahead had supercritical technology been chosen instead of sub-critical technology in the

representative case. These results are sensitive to the choice of input assumptions made on the valuation model.

The results are also highly sensitive to changes in fuel prices, with baseline IGCC becoming more cost competitive than PC at higher fuel prices. In the illustrative case, it is seen that an increase in fuel price from \$1.1/million Btu to \$1.5/million Btu makes baseline IGCC the preferred technology choice over sub-critical PC or pre-investment IGCC.

8.2 Scope for Future Work

The problem dimensions and scope in the problem formulated was adequate to answer the specific research questions, but limited to keep the problem tractable. It is possible to expand the scope of the problem to help explore additional research questions. Some areas where future work can be directed are discussed below.

- (i) Existing “point” designs of PC, baseline IGCC and pre-investment IGCC that were investigated in this thesis could be expanded to study several variants of these technologies that are known to exist. Combined technical and economic evaluation could be carried out by integrating process flow model of these technologies with the investment valuation tool that has been developed.
- (ii) Other non-coal based technologies like NGCC and nuclear power that compete with coal-fired power could be integrated into the analysis.
- (iii) The “all-equity” project funding basis could be extended to analyze the impact of debt funding in future work.

- (iv) While the current analysis considers CO₂ price as being the lone stochastic variable, the sensitivity of the optimal technology choice to fuel prices indicates the need to introduce fuel price as the second stochastic variable in future work.
- (v) Future work on expert elicitation should focus on dynamic resolution of price uncertainty,⁷⁸ and joint elicitation of CO₂ and fuel prices and their correlation to the overall economy.⁷⁹

⁷⁸ This will provide a basis for arriving at the half life of short term volatilities.

⁷⁹ This will help refine the estimation of 0.4 for the price of risk. Discussion of correlation as one of the factors influencing the price of risk in the Capital Asset Pricing Model is discussed in Chapter 6.