



GHGT-10

Using auxiliary gas power for CCS energy needs in retrofitted coal power plants

Sarah O. Bashadi^a, Howard J. Herzog^{a*}

^aMIT Energy Initiative, Massachusetts Institute of Technology, E19-370L, 77 Massachusetts Avenue, Cambridge, MA 02139

Abstract

Adding post-combustion capture technology to existing coal-fired power plants is being considered as a near-term option for mitigating CO₂ emissions. To supply the thermal energy needed for CO₂ capture, much of the literature proposes thermal integration of the existing coal plant's steam cycle with the capture process' stripper reboiler. This paper examines the option of using an auxiliary natural gas turbine plant to meet the energetic demands of carbon capture and compression. Three different auxiliary plant technologies were compared to integration for 90% capture from an existing, 500 MW supercritical coal plant. CO₂ capture (via a monoethylamine (MEA) absorption process) and compression is simulated using Aspen Plus. Thermoflow software is used to simulate three gas plant technologies. In some circumstances, it is found that using an auxiliary natural gas turbine may make retrofits more attractive compared to using thermal integration. The most important factors affecting desirability of the auxiliary plant retrofit are the cost of natural gas, the full cost of integration, and the potential for sale of excess electricity.

© 2011 Published by Elsevier Ltd.

Keywords: Carbon capture and sequestration; CCS; Post-combustion capture retrofits

1. Introduction

Given the significant reliance on coal-fired power plants today and the projected growth in electricity demand worldwide, coal will remain an important energy supply technology for decades to come [1]. Retrofitting these plants with post-combustion CO₂ capture (PCC) technologies has been suggested as a possible means of reducing CO₂ emissions [2]. However, PCC retrofits are projected to give plant operators an unattractive proposition of not only investing hundreds of millions of dollars, but also reducing the coal-fired power plant's net power output by about 30% [3,4].

Most PCC retrofit studies have focused on CO₂ capture technologies but few have devoted attention on how to provide the significant amount of heat and power required by the PCC process. Much of the literature proposes thermal integration of the existing coal plant's steam cycle with the capture process' stripper reboiler. This study compares thermal integration to using an auxiliary natural gas plant to meet the energy needs of PCC retrofits. First, the technical changes required using the integration approach and its limitations are discussed. Next, the methodology for comparing the integration approach to multiple types of auxiliary gas plants is outlined. Finally, the results of the economic assessment and the tradeoffs from each approach are presented.

2. Thermal Integration

In PCC processes, the decrease in electricity production from the base plant due to the diversion of steam from the low-pressure (LP) turbine has been reported to cause a 20-30% decrease in the base plant's net power output [3,4]. Though some understanding exists about the task of extracting steam from the power cycle in a retrofitted plant, the issues surrounding its practical implementation are significant and deserve considerable attention.

One of the key parameters guiding the turbine modifications that will be necessary is the steam pressure and temperature usable in the desorption column reboiler. For an MEA absorption system, a consensus exists that the reboiler should use saturated steam at approximately 130-135°C and 3 bar. Steam should be extracted from the turbines as close as possible to this

* Corresponding author. Tel.: +1-617-253-0688; fax: +1-617-253-8013
E-mail address: hjherzog@mit.edu.

pressure to maximize the amount of power generated in the steam turbines. However, the potential for higher and lower pressure steams in the reboiler arising from solvent improvements make it difficult for plant operators and engineers to choose a system configuration. Though MEA may remain the most attractive option for at least the near-term, changes in the regeneration steam pressure requirements will affect the efficiency of and amount of plant output lost from the power cycle.

Steam turbine modifications for extraction show little flexibility in regeneration pressure, complicating the selection of turbine modifications that appropriately balance flexibility and maximizing power output. The literature generally discusses three different options for steam turbine modifications: using a clutched LP turbine, throttled LP turbine, or floating IP/LP crossover pressure [3,5,6]. These options are illustrated in Figure 1.

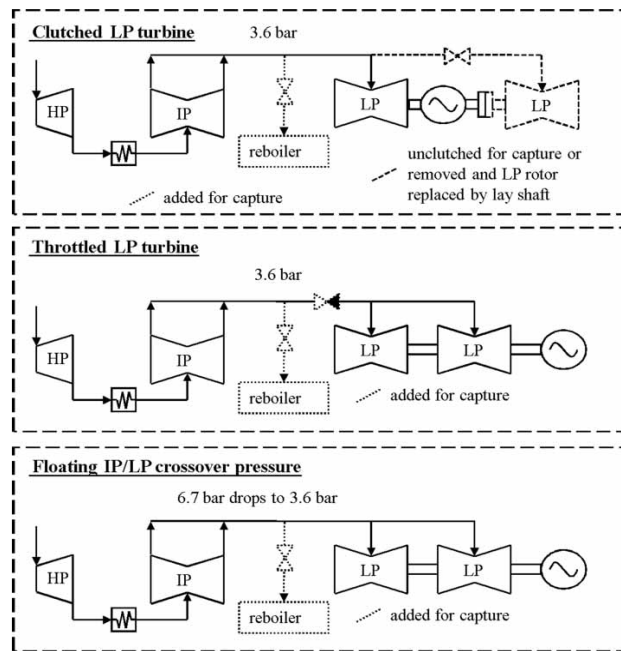

Figure 1 Potential Steam Turbine Modifications for Integrated Retrofits

In the clutched LP design, the steam needed for the reboiler would be withdrawn from an IP/LP crossover pipe at a pressure based upon the specific solvent system. The mass flow of the steam not extracted from the IP/LP crossover pipe would match the design mass flow of either one or two of the original LP cylinders to maximize the efficiency of the remaining steam. The LP cylinder(s) no longer in use would have to be decommissioned. The principal advantage of this approach is that the engineering performance is maximized; the upfront costs, however, are expected to be higher than in the other two approaches [7]. From an operational standpoint, the major problem with this approach is the lack of flexibility in the percentage of steam diverted to the retrofit.

In the throttled LP turbine, the IP/LP crossover pipe would be designed to provide steam at the pressure needed for solvent regeneration. Steam not extracted from the IP/LP crossover pipe would be throttled to maintain crossover pressure, resulting in throttling losses and decreased efficiency but variable stream extraction rates. The flexibility in percentage of steam extracted provides a significant benefit in light of the expected improvements in capture technologies. The initial investment for this design would also be lower than the other two options since new purchases would be limited to equipment required for steam offtake.

Greater flexibility towards the percentage and pressure of the steam extracted can be obtained using a floating IP/LP crossover design. In this approach, the pressure in the IP/LP crossover pipe is designed to fall to the desired pressure when the specified amount of steam is extracted. The last stages of the IP turbine and initial stages of the LP section would have to be rebuilt in order to handle a range of temperatures and pressures. In addition, valves would be installed downstream of the extraction offtake or before the LP cylinders to accommodate higher and lower steam flows, respectively. However, as with the clutched LP design, the optimal efficiency is obtained when the turbines are designed for the operational amount of steam needed in the reboiler. This approach results in moderate up-front costs due to the required rebuilding of the last stages of the IP cylinder to handle possible axial thrust changes for single flow units, higher blade bending moments, and flow restrictions. Table 1 summarizes the performance of the various integration approaches. Regardless of the approach taken, plant operators will face expensive downtime, extensive turbine modifications, additional capital costs, and efficiency losses in the coal plant.

Table 1 Assessment of Integration Options.

	Clutched LP turbine	Throttled LP turbine	Floating pressure turbine
Efficiency penalty	Low	High	Medium
Capital investment	High	Medium-low	Medium
Option for solvent change	No	Lower reboiler pressure only	Higher or lower reboiler pressure
Option to have lower steam requirements	No	Yes	Yes

3. Methodology

In order to assess the feasibility of using an auxiliary power plant to provide the electricity and steam needed for a PCC retrofit, a case study for an existing, fully amortized supercritical pulverized coal plant has been developed. The base plant selected was a 500 MW_e supercritical pulverized coal power unit as detailed in the 2007 MIT Future of Coal study [1]. The plant uses Illinois #6 bituminous coal with 61.2 wt% carbon content and operates at a heat rate of 8870 Btu/kWh (38.5% HHV efficiency). A PCC process that captures 90% of the CO₂ in the stack gas was simulated in Aspen Plus, and the associated steam and power needs were calculated. To supply the energy needed for a PCC retrofit, four different technological processes that could meet the capture unit energy needs were then evaluated. The first option was thermal integration of the steam cycle of the coal plant with the capture plant. The other three options used an auxiliary natural gas power plant for the energy needed in the capture plant. The cost of the capture plant was estimated using Aspen Icarus; the cost of the auxiliary natural gas plant was estimated using Thermoflow PEACE.

3.1. Capture Plant Scenarios

3.1.1. Scenario A: MEA Capture Plant

Scenario A considers a typical MEA-based CO₂ capture plant that could be built today. Using an Aspen Plus simulation [8], the MEA scrubbing plant was specified to achieve 90% removal of CO₂ in the base plant flue gas. The energy balances from the simulation are used to calculate the power and steam needs for the MEA process and are found to be consistent with other studies [1,3,9]. The thermal energy needed is the desorption column reboiler duty of 445 MW_{th} or 4.29 GJ/tCO₂. The work needed for compression and auxiliary needs is 64 MW_e. After calculating the work lost from steam extraction (67 MW_e), the total power output reduction from the 500 MW_e coal-fired plant in an integrated design is 131 MW_e.

3.1.2. Scenario B: High Electricity to Steam: Solvent

In Scenario A, the CO₂ capture energy needs was based on 64 MW_e of electrical power needed for compression and auxiliary equipment and 445 MW_{th} of steam needed for the reboiler. In order to understand the effect of an alternative energy distribution in the CO₂ capture island, the total overall plant derating was kept the same (i.e., 131 MW_e), but the heat to power ratio was assumed to be lower. Specifically, heat to power requirements of about 50:50 in Scenario A were assumed to be 35:65 in Scenario B. This new scenario is roughly based on a chilled ammonia capture process [8]. While chilled ammonia may be able to reduce total energy demands (i.e., the 131 MW_e), it is kept constant here to focus solely on the effects of changes in the heat to power ratio. The pressure of the extracted steam is kept the same in both scenarios at 3.0 bar.

3.2. Natural Gas Auxiliary Plant Cases

3.2.1. Natural Gas Turbine with Heat Recovery Steam Generator

This auxiliary gas power plant design uses the high capacity GE 7251FB turbine (Case 1GE) or Siemens SGT6-6000G turbine (Case 1S) with a dual pressure heat recovery steam generator (HRSG) for steam generation. The HRSG is designed to produce steam at 30 bar in the high pressure section in order to limit the size of the HRSG. The steam withdrawn equally from the HP and IP superheaters is throttled to 5 bar and 152°C using valves. Condensate from the reboiler is returned to the external plant at 32°C and fed to the condensate preheater in the HRSG with a small amount of make-up of water. Using a 10°C pinch in the HRSG, 1.6 theoretical Siemens turbines could be used to produce sufficient steam for Scenario A (Case 1S-A), while only 1.0 turbines are needed for Scenario B (Case 1S-B). Using the GE turbine, 2.0 and 1.4 turbines were necessary for Scenario A (Case 1GE-A) and Scenario B (Case 1GE-B).¹

3.2.2. Natural Gas Turbine with HRSG and Back Pressure Steam Turbine

This dual pressure combined cycle plant uses a back pressure steam turbine set at 5 bar to produce steam. This stream is desuperheated to 149°C and 4.7 bar using water from the HRSG IP section. The combined cycle plant was designed to produce

¹ For the study, the auxiliary power plants were sized to exactly meet the steam requirements of the capture plant, since this is the most energy efficient design. Because we only considered one size of gas turbine, we ended up with a fractional number of turbines. While this is not realistic from the point of view of actually building a plant, it is adequate to compare the cost and performance of the various cases outlined in this paper.

as much low pressure steam as possible using a 10°C pinch temperature and no supplementary firing in the HRSG. Condensate from the reboiler is returned to the preheaters in the HRSG at 32°C. Using a GE 7251FB turbine, 2.4 gas turbines with their associated HRSGs and steam turbines were necessary for Scenario A (Case 2GE-A), and 1.6 turbines were necessary for Scenario B (Case 2GE-B). Using the larger Siemens turbine, 1.8 and 1.3 turbines were needed for Scenario A (Case 2S-A) and Scenario B (Case 2S-B), respectively.

3.2.3. Natural Gas Boiler with Back Pressure Steam Turbine

The last type of natural gas cogeneration design considered is a natural gas-firing boiler with back pressure steam turbine. The back pressure of the steam turbine was set at 5 bar, but unlike in previous cases, one train of equipment (one boiler and steam turbine) is designed to produce all of the steam needed in the capture plant. The steam turbine operates at subcritical conditions of 200 bar and 570°C. Four feedwater heaters are used to heat the reboiler condensate before being returned to the boiler.

4. Results

4.1. Scenario A – MEA Capture Plant

The auxiliary gas plants are compared to thermal integration of an MEA absorption process with the base coal plant for a PCC retrofit. Besides the capital investment of the capture plant, the cost of thermal integration from the loss in efficiency, reengineering and downtime, and additional expenditures necessary is difficult to estimate and will vary depending on the characteristics of the coal plant. Three different levels of integration costs were studied to take into account this variability (Table 2). The integration plant cost factor is a scaling factor for the CO₂ capture plant capital cost which accounts for the cost of capture equipment plus the “integration cost.” Integration level A assumes the integration cost is 25% of the capital cost of the capture/compression plant, level B assumes 50% and level C assumes 100%. The total costs vary from \$399 to \$639 MM, though the power output and emissions rate is unchanged in each case. These integration cost levels will show how as integration becomes more challenging and costly, the relative desirability of the integration option changes compared to an auxiliary plant.

Table 2 Summary of Performance for Integration Cases.

	Integration Plant Cost Factor	Capital Cost incl. Capture Plant (\$MM)	Net Output (MW)	COE (€/kWh)	CO ₂ Emissions (kg/kWh)
Integration Level A (I-A)	1.25	399	369	8.3	0.11
Integration Level B (I-B)	1.5	479	369	8.7	0.11
Integration Level C (I-C)	2.0	639	369	9.7	0.11

The technological and economic performance of the five auxiliary plant options under Scenario A are presented in Table 3. The cost and emissions metrics for the external plant cases summarize the performance of the aggregate base plant/MEA plant/external plant system. The large steam demands in this scenario result in significant excesses of electricity in the auxiliary plants and economics that are highly sensitive to fuel costs. The combined cycle gas turbine option appears to slightly outperform the gas turbine only approach despite its high capital cost because it is the most energy efficient, i.e., it most effectively cogenerates heat and electricity. The gas turbine only cases give a similar performance profile as the CCGT option, but at a lower capital cost, reduced natural gas feed rate, and lower total power output. The boiler lags in all performance indicators because it is the least energy efficient.

Table 3 Summary of Performance of Auxiliary Plant Cases under Scenario A.

	Capital Cost incl. Capture Plant (\$MM)	Ext. Plant Efficiency (HHV)	Net Output (MW)	COE (€/kWh)	CO ₂ Emissions (kg/kWh)
Case 1GE-A	629	32.3	790	9.0	0.30
Case 1S-A	629	33.9	827	8.9	0.30
Case 2GE-A	768	40.2	957	8.8	0.29
Case 2S-A	765	41.4	999	8.7	0.29
Case 3-A	626	24.3	651	10.2	0.31

The total plant costs (TPC) of the external plants for an MEA capture plant varied significantly as shown in Table 3. No significant price difference was seen regardless of whether a Siemens or GE gas turbine was used. The combined cycle auxiliary plants' cost (excluding the capture plant costs) was approximately 50% higher in cost than the simple gas turbine or boiler plants.

The aggregate power output and emissions rate from the integration and auxiliary plant options are substantially different. In the integration case, the power output drops to 369 MW due to the energy withdrawn from the coal plant for the capture island. The external plant cases increase the total output of the aggregate system from the base plant size of 500 MW after supplying the energy needed for the capture island. The gas turbine only cases, Cases 1GE-A and 1S-A, increase power output on average by 308 MW. Cases 2GE-A and 2S-A, the combined cycle plants cases, raise power production on average by 478 MW, and the boiler case, Case 3-A, raises the aggregate output by 151 MW.

In this study, we did not consider the option of capturing the emissions from the auxiliary plant, but simply vented the CO₂ emissions to the atmosphere. As a result, the emissions rate using an auxiliary power plant is about 2.6 times the rate observed when using integration. However, compared to the emissions rate for the uncontrolled coal-fired power plant (0.83kg/kWh), this represents a 64% decrease.

This study used the 2010 natural gas price for power plants of \$5.37/MMBtu. The COE includes the O&M, fuel (coal and if applicable, natural gas), and capital costs. The base plant COE of 3.9¢/kWh includes no capital cost component because it is assumed to be fully amortized. The COEs for the various cases are compared in Figure 2.

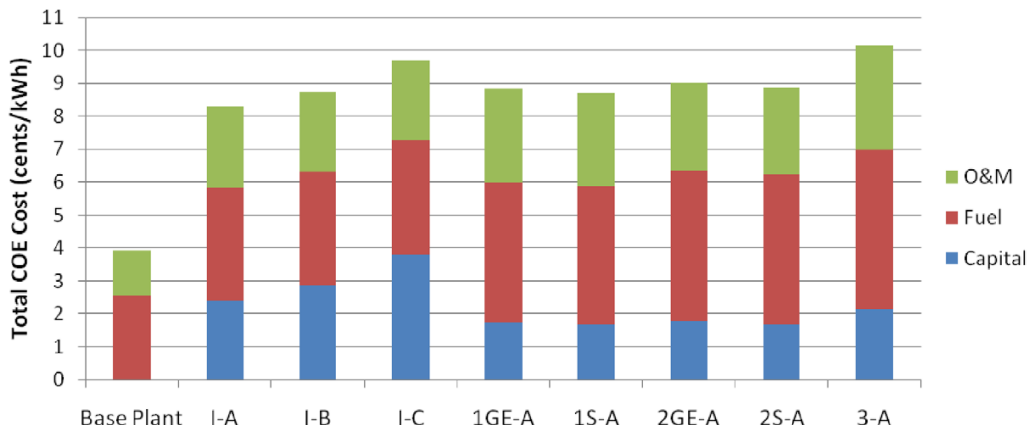

Figure 2 Cost of Electricity for Base Plant and Retrofit Cases in Scenario A.

The cost of electricity using an external plant changes by about 1.5 ¢/kWh when the natural gas price is scaled by 0.5 or 1.5 from the 2010 natural gas price. This is due to high volumes of natural gas being used in the external plant cases, particularly in the combined cycle plants. The projections for natural gas fuel prices over the lifespan of the external plant will have a strong impact on the favorability of the auxiliary plant retrofit options versus integration.

To understand how changes in natural gas price and integration costs estimates would affect the performance of the two major retrofit approaches, Case 2S-A (Siemens CCGT) economics are examined as a function of both natural gas price and integrated plant cost. The results (Figure 3) show that when natural gas fuel prices are at 1.5 times the current price, only at an integrated plant cost factor of around 2 is the COE of Case 2S-A as low as the COE for integration. On the other hand, with low natural gas fuel prices of half of today's prices, Case 2S-A has a lower COE than integration regardless of the level of integration difficulty.

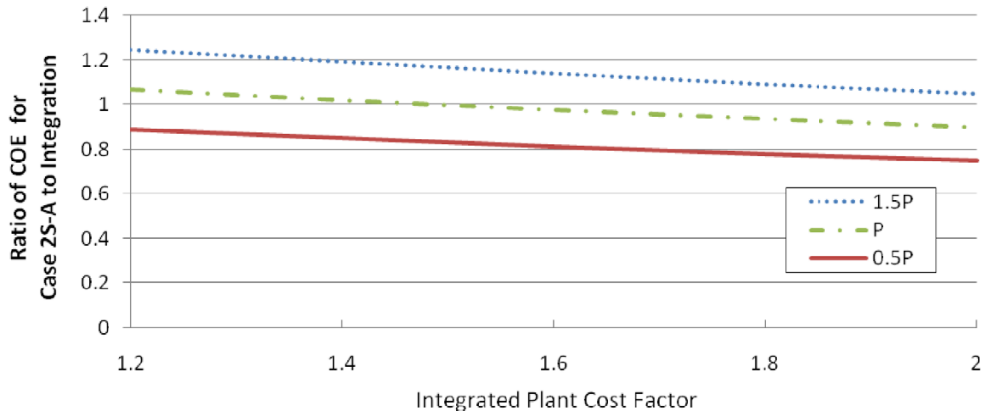

Figure 3 Sensitivity of Ratio of COE for Case 2S-A and Integration to Natural Gas Fuel Price and Integrated Plant Cost.

4.2. Scenario B - High Electricity to Steam Solvent

In Scenario B, this energy distribution is changed to 65% of 131 MW_e of power loss due to electricity needs and 35% of the total 131 MW_e loss due to extraction of turbine steam. Given a lower heat (i.e. steam) requirement in the capture island in Scenario B, the number of theoretical gas turbines necessary to generate the required amount of steam was recalculated for Cases 1 and 2. The gas boiler of Case 3 was redesigned to produce exactly the amount of steam needed.

Table 4 Summary of Performance of Auxiliary Plant Cases under Scenario B.

	Capital Cost incl. Capture Plant (\$MM)	Ext. Plant Efficiency (HHV)	Net Output (MW)	COE (€/kWh)	CO ₂ Emissions (kg/kWh)
Case 1GE-B	531	32.3	657	8.83	0.27
Case 1S-B	521	32.8	666	8.75	0.27
Case 2GE-B	627	40.2	771	8.75	0.26
Case 2S-B	625	41.4	800	8.65	0.26
Case 3-B	546	24	560	9.91	0.27

A summary of the results for the auxiliary plant cases in Scenario B is shown in Table 4. Significantly smaller auxiliary plants are needed compared to Scenario A. Compared to Scenario A, Scenario B requires lower capital costs and results in lower emissions factors and slightly lower COEs. Also, the excess electricity produced in Scenario B is significantly lower than Scenario A.

5. Discussion

Before auxiliary plants can be built around existing coal plants, several requirements must be met. In addition to the space needed for the CO₂ capture unit, sufficient space must exist for the auxiliary plant. Access to natural gas pipelines must be available for firing in the auxiliary plant. Finally, and perhaps most critically, sufficient regional demand must exist for the excess power produced by the auxiliary plant. As discussed, the amounts of excess power generated by the auxiliary plant can be on the order of hundreds of megawatts of electricity for a 500 MW coal plant. If the auxiliary plant's variable costs of electricity are low enough to ensure dispatch, the profitability of a retrofit could be improved using an auxiliary plant. Before the excess electricity could be sold, however, improvements to transmission lines and infrastructure around the plant may be necessary to handle an increased load, already a growing national concern [10]. Nonetheless, if sufficient demand and infrastructure are in place and its electricity costs are low compared to integration, the increase in power output can make retrofits more attractive to implement.

Auxiliary plants also introduce economic uncertainty due to the plant's operating profit dependence upon natural gas prices. As seen in Figure 3, depending upon the natural gas price, auxiliary plants could make retrofits more (or less) affordable for operators to install relative to integration. Even when a high electricity to steam solvent is used in the capture plant enabling construction of smaller plants and less natural gas usage, the relative affordability of integration and auxiliary plants still shows sensitivity to natural gas prices.

Another important factor affecting the economics of integration versus auxiliary plant is the cost of integration. This includes both the expected costs arising from the turbine modifications and the efficiency loss arising from steam extraction. If the integration costs are expected to be substantial and the loss in power output and efficiency penalty associated with these modifications are expected to be significant, the auxiliary plant option may provide cost savings, making retrofits a more feasible path forward. An auxiliary plant retrofit, while having higher upfront capital costs, would eliminate the risk of a costly integration process that also decreases the plant's power output. The new gas plant would use mature gas turbine technology and could be built from the ground-up to meet the energetic needs of the capture plant. In addition, an integrated base plant requires turbine modifications particularly designed for a specific amount and pressure of extraction steam as discussed in Section 2. In contrast, an auxiliary plant designed for steam generation would offer more flexibility for changes in capture plant steam conditions.

The natural gas auxiliary plant option also brings with it specific features that can make it a more burdensome retrofit option than integration. From the perspective of percentage of total carbon emissions captured, the auxiliary natural gas plant retrofit does lead to a lower total percentage captured, leaving operators susceptible to higher CO₂ prices in the future and essentially "on-the-hook" for the additional CO₂ emissions. Capturing the CO₂ in the auxiliary plant flue gas is possible but would require an additional capture plant or mixing with the coal plant flue gas, leading to additional costs.

Certain barriers to retrofit remain the same no matter which retrofit path is taken. These include difficulty of retrofitting inefficient power plants, strict requirements on SO₂ and NO_x concentrations in the flue gas, and access to storage sites.

Natural gas-based cogeneration may be more attractive in the long-term because of its resilience to the pressures of long-term energy market trends. Consistent growth in electricity consumption will lead to a greater call for baseload electricity generation over the next two decades. According to the EIA, 259 GW of new capacity will be needed in the next two decades in the US, roughly three-fourth the size of the current coal fleet [11]. The expectation of stricter emission standards also has created a push towards using cleaner fuels, and natural gas has emerged as the preferred fuel until the exact nature of regulatory standards are known [12]. Natural gas plants are attractive for new builds because they are easy to site, have short construction times, and operate with high efficiency. Because natural gas plants have a higher efficiency and lower carbon dioxide intensity than traditional fossil-fuel (petroleum or coal) power plants, natural gas use is projected to increase rapidly over the next fifteen years [12]. Lastly, the affordability of the external plant option appears primed to benefit from the recent advances in producing natural gas from shale formations.

As a final thought, some argue that it is in the national interest to save the coal fleet using CCS, while others say we should simply replace coal plants with natural gas. In this paper, we show a way forward that combines these two arguments. Specifically, we analyze the pathway of continuing to get the benefits of our existing coal fleet in a greenhouse gas constrained world by using both CCS and natural gas to help reduce its CO₂ emissions.

6. Acknowledgements

This paper is based on research conducted at MIT from September 2008-May 2010. We would like to thank the MIT Carbon Sequestration Initiative and the MIT-NTNU collaborative research program (sponsored by Statoil Hydro and the Norwegian Research Council) for their financial support of this research effort. A more detailed account of this research effort can be found in Sarah Bashadi's MS Thesis [13].

References

- [1] Massachusetts Institute of Technology. The Future of Coal: Options for a Carbon-Constrained World. 2007. <<http://web.mit.edu/coal/>>
- [2] Massachusetts Institute of Technology Energy Initiative. Retrofitting of Coal-Fired Power Plants for CO₂ Emissions Reductions. 2009. <<http://web.mit.edu/mitei/research/reports.html>>
- [3] Romeo L, Bolea I, Escosa J. "Integration of Power Plant and Amine Scrubbing to Reduce CO₂ Capture Costs." *App. Thermal Engr.* 2008; 28.
- [4] Alstom Power Inc, ABB Lummus Global Inc, and American Electric Power Inc. Engineering Feasibility and Economics of CO₂ Capture on an Existing Coal-Fired Power Plant - Final Report. Submitted to Ohio Department of Development. PPL Report No. PPL-01-CT-09. 2001.
- [5] Lucquiaud M, and Gibbins J. Retrofitting CO₂ Capture Ready Fossil Plants with Post-combustion Capture. Part 1: Requirements for supercritical pulverized coal plants using solvent-based flue gas scrubbing. *Proc. IMechE, Part A: J. Power and Energy.* 2009; 223.
- [6] Alie C. CO₂ Capture with MEA: Integrating the Absorption Process and Steam Cycle of an Existing Coal-Fired Power Plant. Master's thesis, University of Waterloo, 2004.
- [7] Liang X, Reiner D, Gibbins J, Li J. Assessing the Value of CO₂ Capture Ready in New-Build Pulverised Coal-fired Power Plants in China. *Int. J. of Greenhouse Gas Control.* 2009; 3:787-92.
- [8] Kothanadamaran A. Carbon Dioxide Capture: A Solvent Comparison Study. Ph.D. Dissertation, Massachusetts Institute of Technology. Cambridge: 2010.
- [9] Abu-Zahra MRM, Schneiders LHJ, Niederer JPM, Feron PHM, Versteeg GF. CO₂ Capture from Power Plants Part I. A parametric study of the technical performance based on monoethanolamine. *Int. J. Greenhouse Gas Control.* 2007; 1:37-46.
- [10] North American Electric Reliability Corporation. 2009 Long-Term Reliability Assessment. Princeton, N.J.: NERC. 2009.
- [11] Annual Energy Outlook 2009. Energy Information Administration, 2009.
- [12] International Energy Outlook 2009. Energy Information Administration, May 27, 2009.
- [13] Bashadi, S., "Using Auxiliary Gas Power for CCS Energy Needs in Retrofitting Coal Power Plants," M.I.T. Masters Thesis, June (2010). <http://sequestration.mit.edu/pdf/SarahBashadi_Thesis_June2010.pdf>